

# Accelerator R&D Roadmap

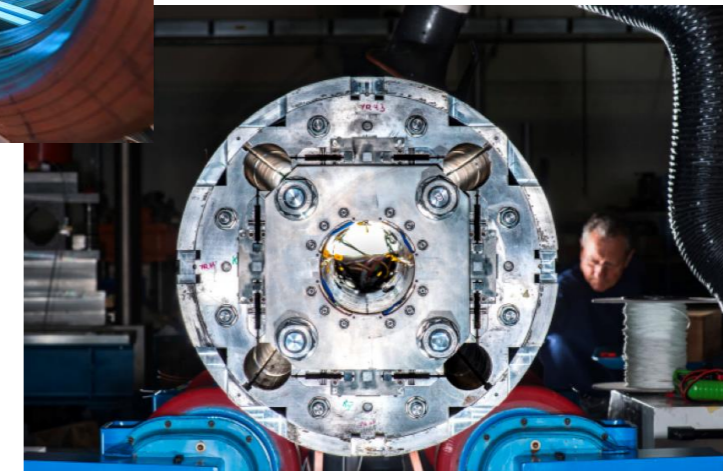

[arXiv:2201.07895v2](https://arxiv.org/abs/2201.07895v2)

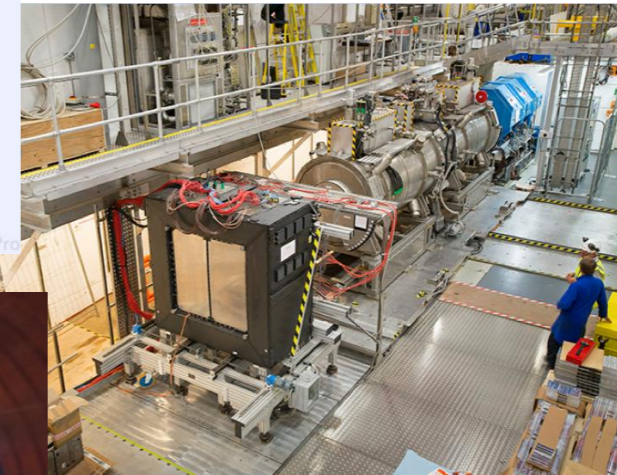
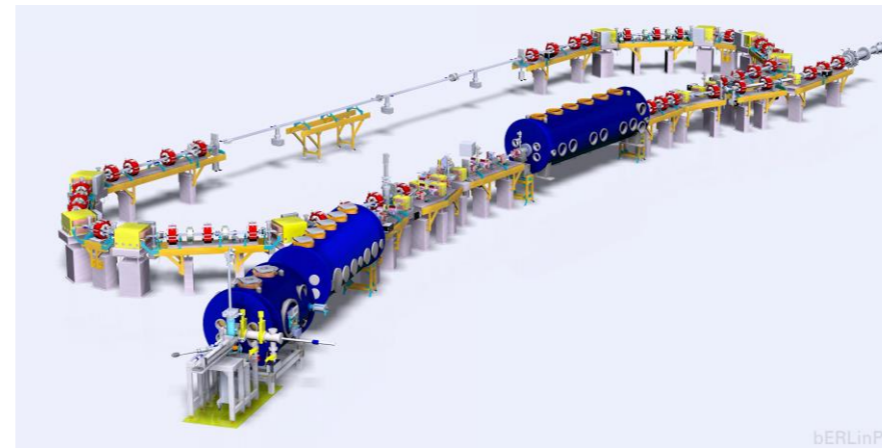

Lenny Rivkin  
Chair, CERN Scientific Policy Committee  
Former Chair of Laboratory Directors Group

# Motivation and Scope

## ▶ European Strategy (2020 update) contains clear recommendations on accelerator R&D:

- ▶ *The particle physics community should ramp up its R&D effort focused on advanced accelerator technologies.*
- ▶ *The European particle physics community must intensify accelerator R&D and sustain it with adequate resources; a roadmap should prioritise the technology.*
- ▶ *Deliverables for this decade should be defined in a timely fashion and coordinated among CERN and national laboratories and institutes.*

## ▶ Key messages

- ▶ Implementation is now under way
- ▶ Need to maintain focus on delivery of the future facilities for Particle Physics
  - ▶ Including any intermediate benefits of new technologies
- ▶ Ongoing engagement of the wider Particle Physics community is key

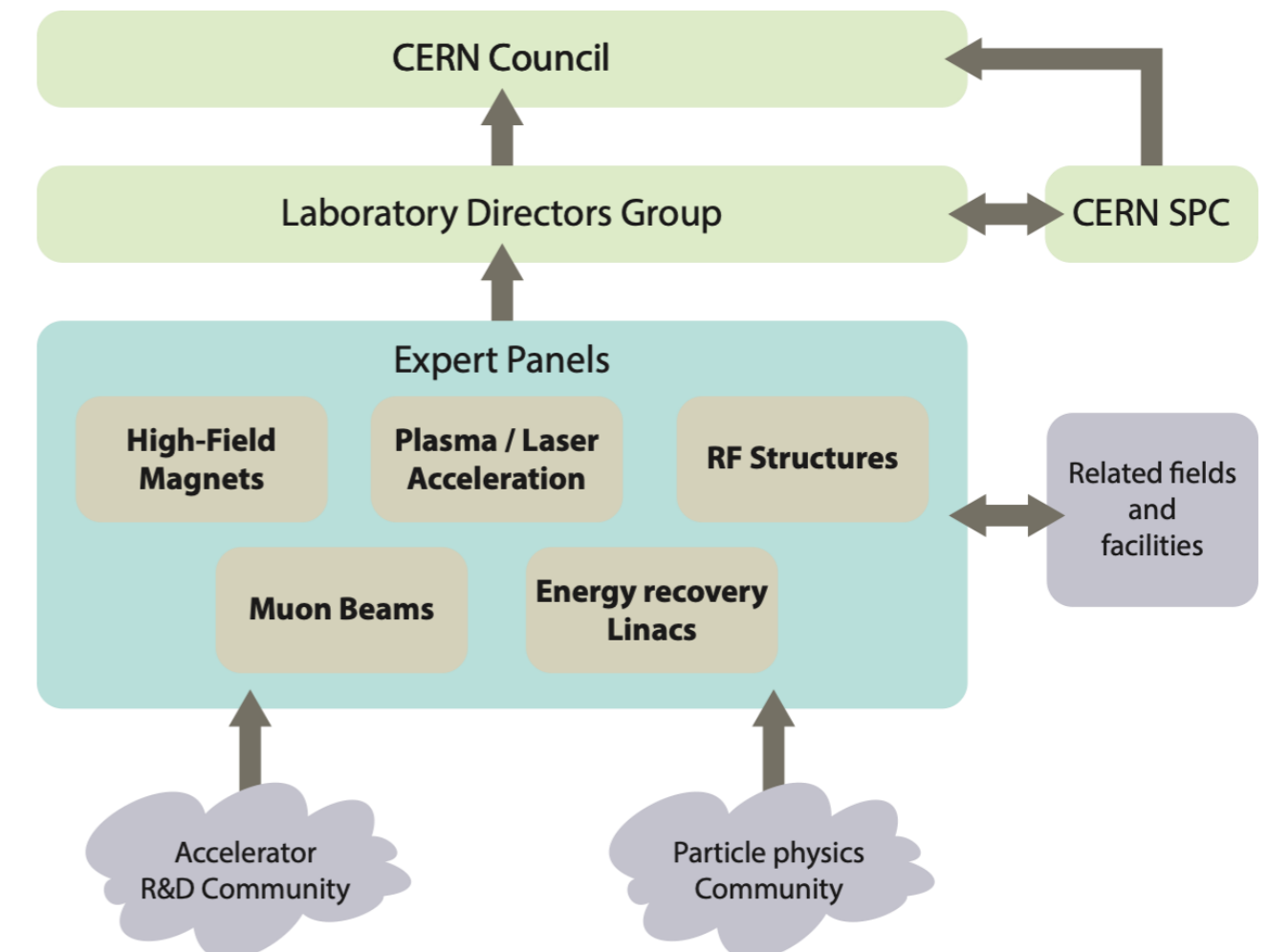

□□

LDG Members: CEA/Irfu (France), CERN, CIEMAT (Spain), DESY (Germany), IJCLab (France), LNF (Italy), LNGS (Italy), Nikhef (Netherlands), PSI (Switzerland), RAL/STFC (United Kingdom)

# Current Status

- ▶ The Roadmap indicated the broad R&D objectives and priorities
  - ▶ But not a detailed execution plan, informed by known resources
- ▶ R&D programme now in the ‘implementation phase’
  - ▶ Clear that in most areas this represents the start of a ramp-up
  - ▶ In some cases, a new community / organisation must be established
  - ▶ For HFM and muons, formal collaborations now exist at CERN
- ▶ Implementation will be formally overseen by Laboratory Directors Group (LDG)
  - ▶ Working within the mandate conferred by CERN Council in March 2021
  - ▶ Symmetry with the ECFA oversight of the detector R&D programme
    - ▶ In both cases, the ‘practical work’ is done by self-organised groups within an approved scope
  - ▶ Frequent updates to SPC via LDG, plus an annual review of progress
- ▶ Participation of the wider HEP community
  - ▶ LDG can monitor and oversee, but does not represent ‘European HEP’ in the widest sense
  - ▶ Need to find routes for ongoing dialogue with / input by the community
    - ▶ The first community workshop on the R&D programme will be held in July 2023
- ▶ Noting that the European R&D is embedded in a wide international programme
  - ▶ See, for instance, Snowmass accelerator frontier report: <https://arxiv.org/abs/2209.14136>

# Coordination Structure

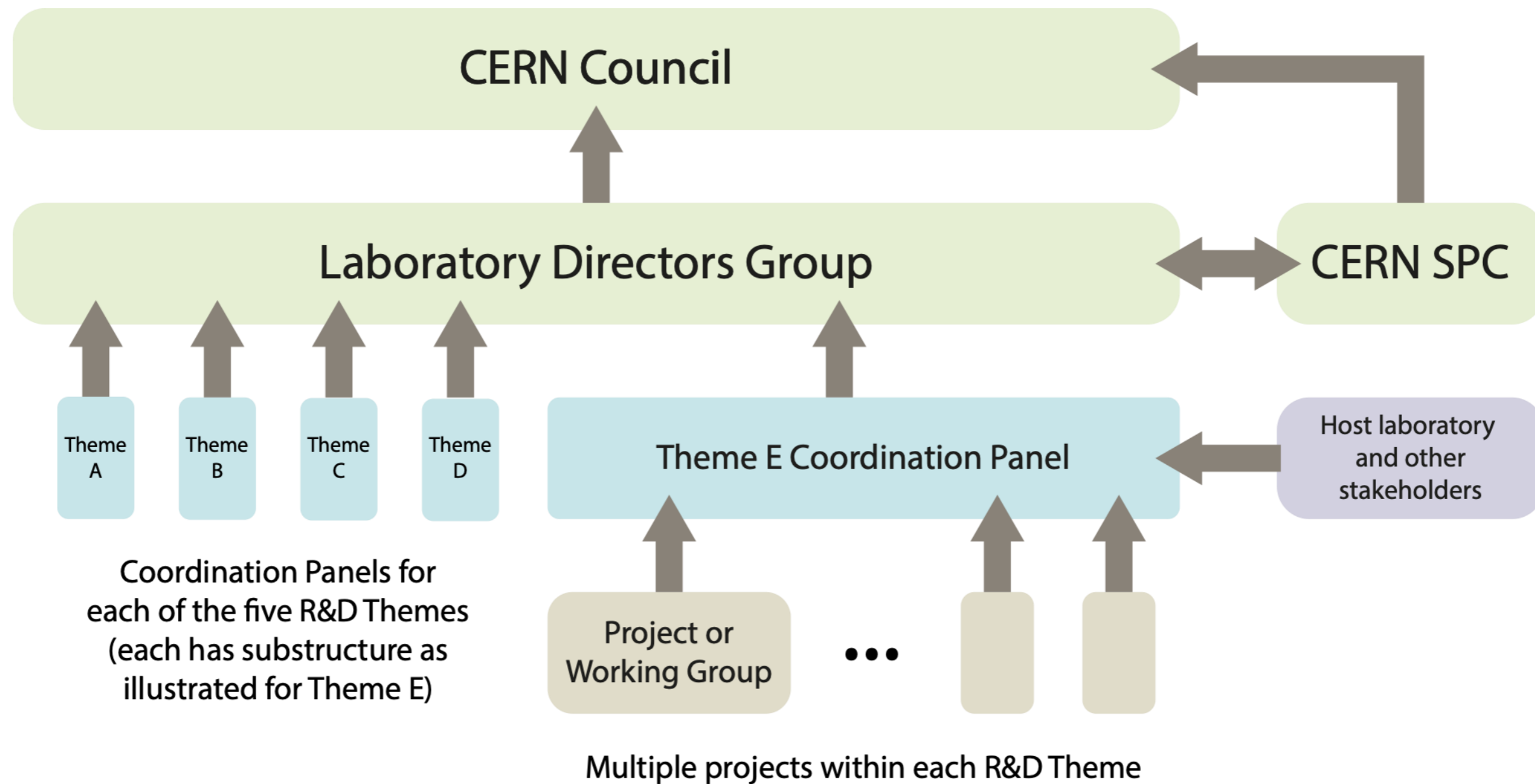

- Important that the door is kept open for new participation in coming years
- Becoming clear that communication between panels is also a key aspect
  - e.g. strong overlap between RF, magnets and muons activities

# Coordination Panel Leadership

## ▶ HFM

- ▶ Mike Lamont (CERN)
- ▶ Pierre Vedrine (IRFU)

## ▶ RF

- ▶ Giovanni Bisoffi (INFN Padova)
- ▶ Peter McIntosh (DL)

## ▶ LPA

- ▶ Wim Leemans (DESY)
- ▶ Rajeev Pattahill (RAL)

□□

## ▶ Muons

- ▶ Steinar Stapnes (CERN)
- ▶ Daniel Schulte (CERN)

## ▶ ERL

- ▶ Jorgen D'Hondt (VUB)
- ▶ Max Klein (U. Liverpool)

## ▶ Nominations invited from laboratories and funding agencies

- ▶ Sought to identify strong technical leadership, with a proper national balance
- ▶ Where a formal collaboration was already in place, names were drawn from the leadership bodies of the collaboration

## ▶ These people are now all in place and working (hard)

- ▶ Please feel free to address comments / questions / inputs directly to them

# Roadmap Resource Estimate

Five-year project resources (MCHF)

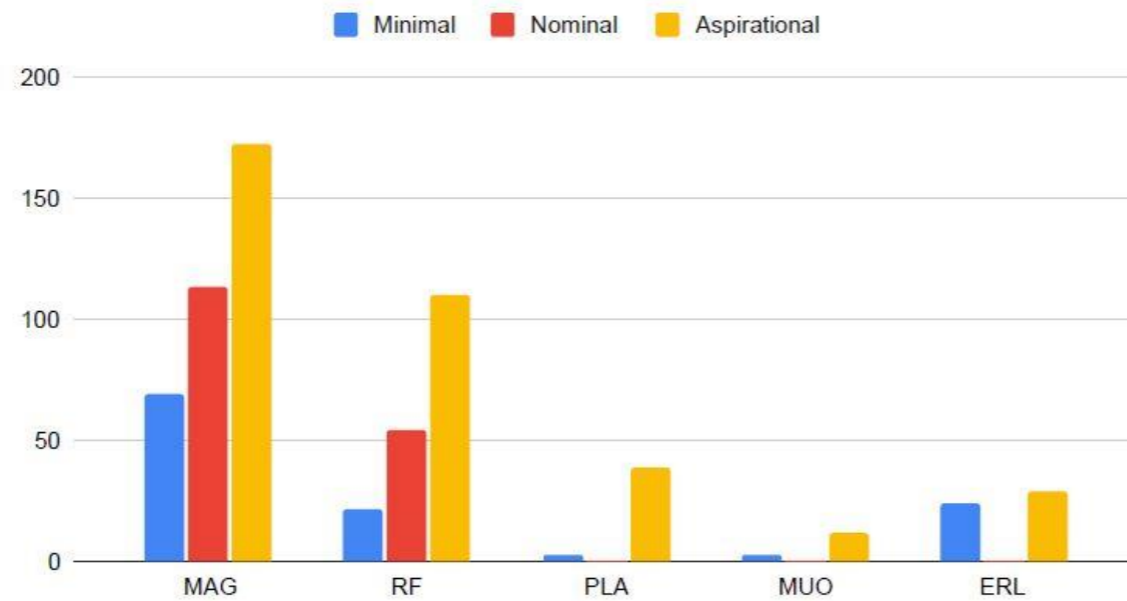

Five-year project staff (FTEy)

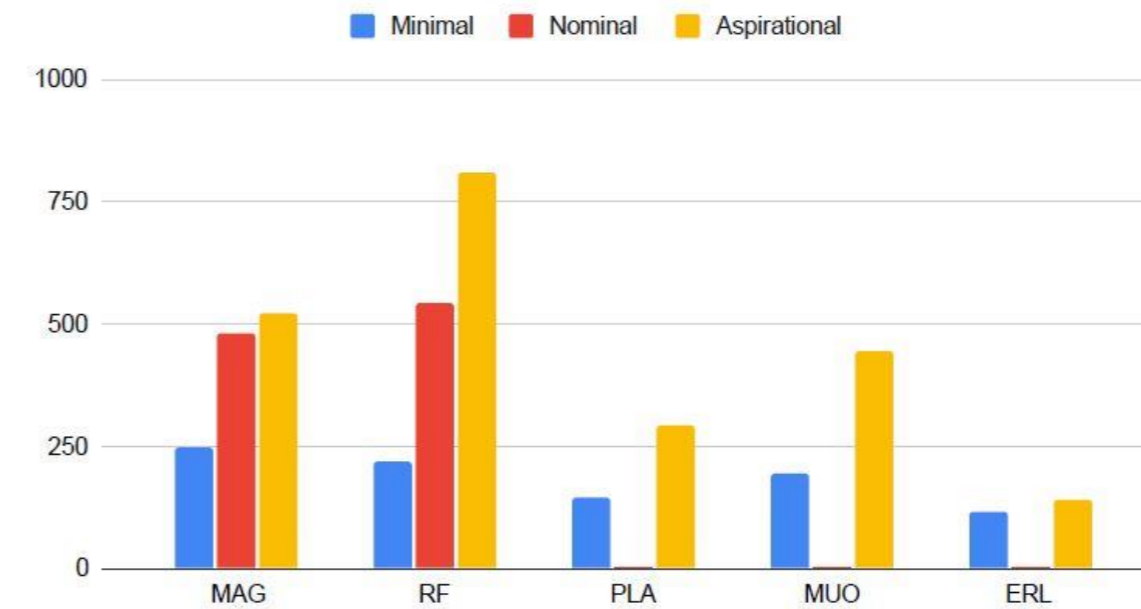

Costs of approved experimental projects with a link to the R&D programme are included within 'contributed resources'

Five-year contributed resources (MCHF)

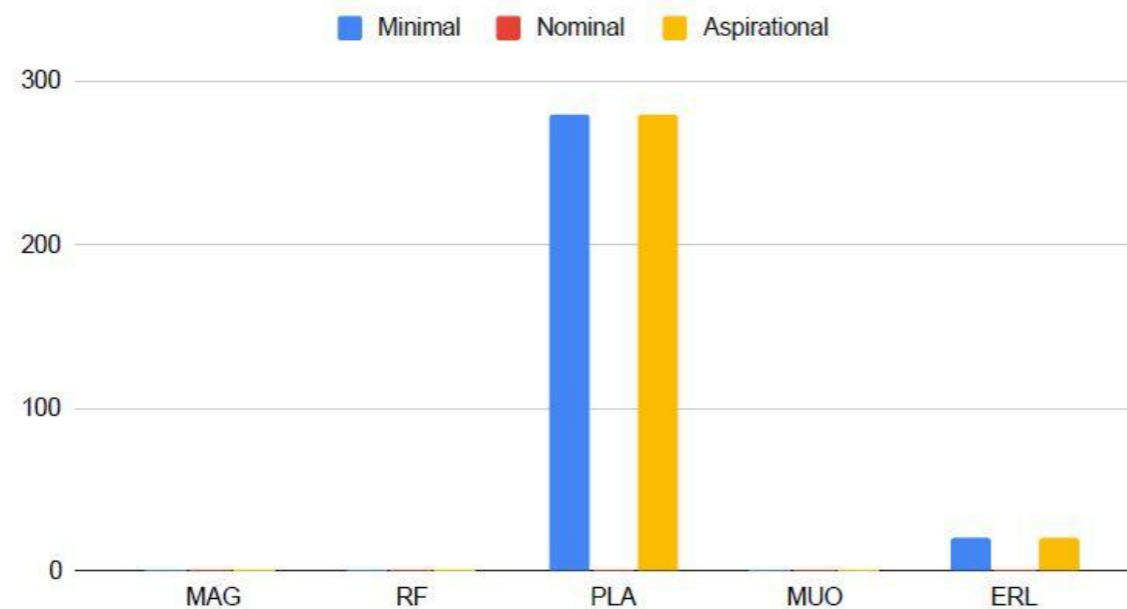

Five-year contributed staff (FTEy)

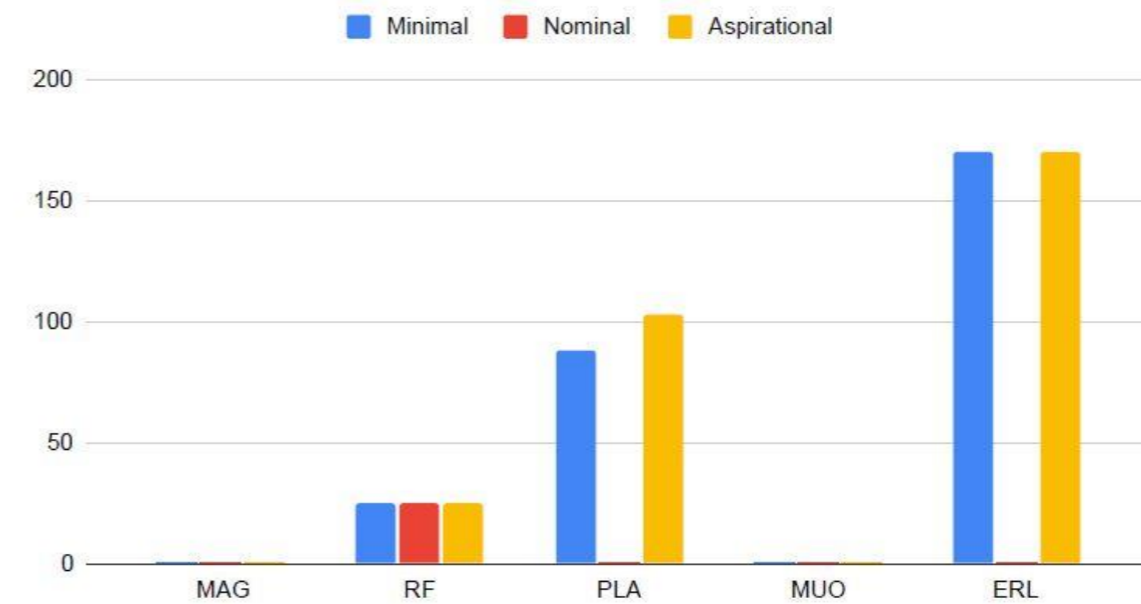

- ▶ Finer-grained resource profile in the roadmap document

# Swiss Accelerator Research and Technology CHART Collaboration



- development of future accelerator technologies  
**Emphasis: high field magnets**
- development of accelerator concepts beyond the existing technology for synchrotron light sources, medical and industrial applications

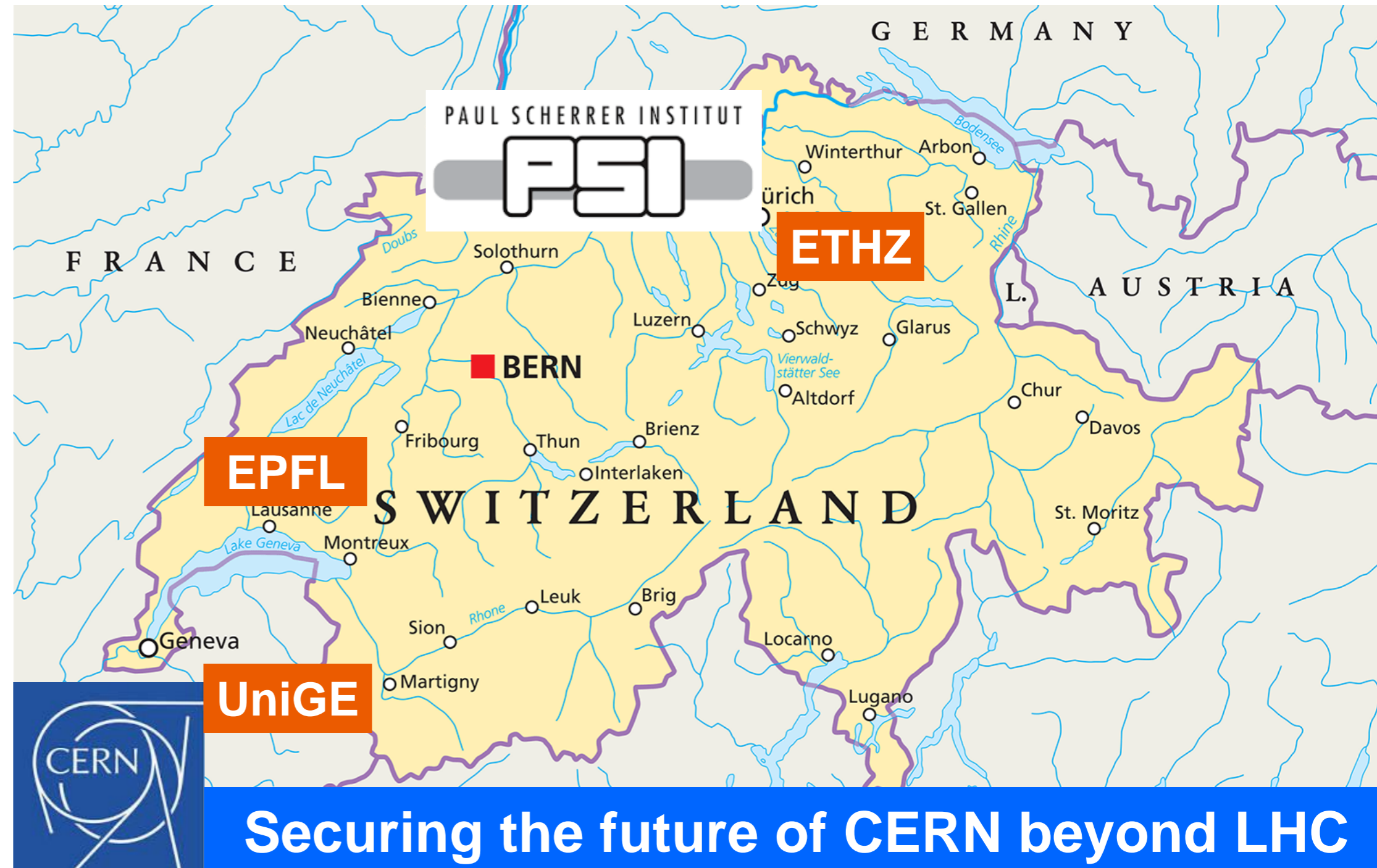

# CHART has demonstrated rapid entry into the High Field Magnet R&D



CHART addressed the need to re-examine some of the basics

- ❖ material science input may be urgently needed to understand the conductor robustness under extreme transverse magnetic pressure and longitudinal forces
- ❖ CHART partners have launched a wide front of such projects
- ❖ Test facilities, allowing for a rapid turn-around of small samples

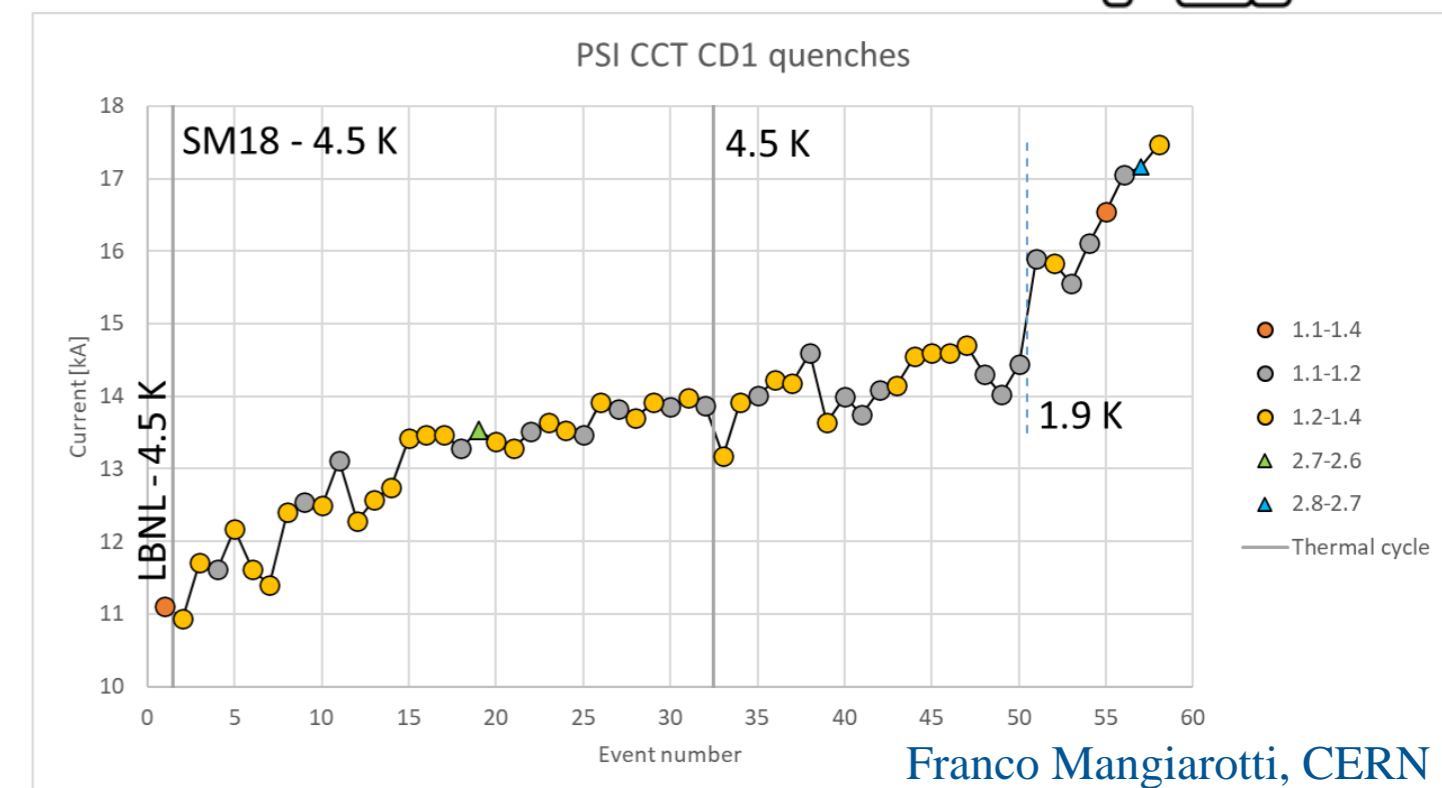



## Collaborating international partners of CHART include:

- [TU Twente](#), Enschede, Netherlands
- [TU Darmstadt](#), Germany
- [USMDP](#) Magnet Development Program, Berkeley, USA
- [University of Cambridge](#), UK
- [LEAPS](#), League of European Accelerator based Photon Sources
- [BNL](#), Brookhaven National Laboratory, USA
- [KEK](#), High Energy Accelerator Research Organization, Tsukuba, Japan
- [IJCLab](#), Laboratoire de Physique des 2 infinis Irène Joliot-Curie, Orsay, France
- [INFN Frascati](#), Italy
- [SLAC National Accelerator Laboratory](#), Menlo Park, USA
- [University of Oxford](#), UK
- [FERMILAB](#), Fermi National Accelerator Laboratory, USA
- [RIKEN SPring-8 Center](#), Japan
- [Kyoto University](#), Japan
- [ESRF](#), European Synchrotron Radiation Facility, Grenoble, France

# HTS superconducting magnet technology undulators



Using bulk HTS material: has reached 2 Tesla for very short period magnets  
Put the structure into a solenoid magnet, cool it and trap the field

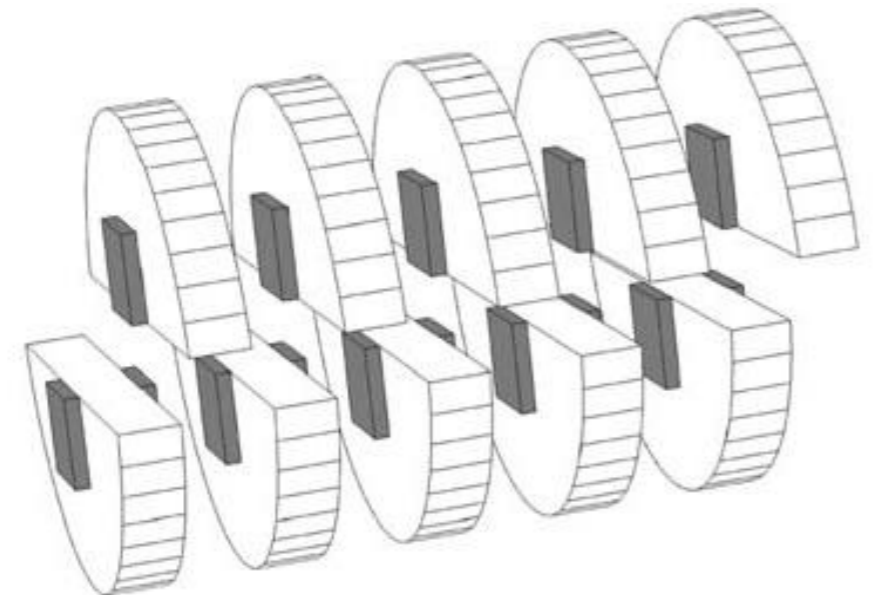

Cooling @ 10T / Solenoid @ 0.0T / 10.0K

