



SPECTRUM X

Spectrum X Overview

Prepared for
National Academies of Science, Engineering and Medicine
Committee on Radio Frequencies (CORF)

Scott Palo

Spectrum X, Associate Director

March 23, 2026

National Radio Spectrum Challenges



FAA issues 5G warning for Boeing 737 radar altimeters, but says practical effects are limited¹

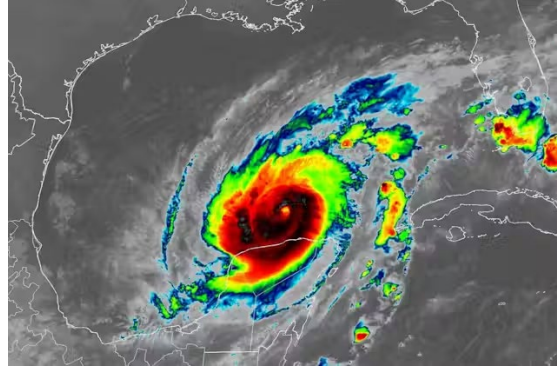

Millimeter wave 5G wireless could interfere with weather forecasts²



The growth of satellite constellations raises concerns about interference with radio astronomy³



Next-generation spectrum workforce is required in a globally competitive environment⁴

The NSF SpectrumX Solution

National-level coordination of world-class interdisciplinary researchers, policy experts, and educators from academia working to solve spectrum coexistence and workforce challenges in collaboration with industry and government.

1 - <https://www.reuters.com/business/aerospace-defense/faa-issues-notice-over-boeing-737s-5g-wireless-interference-2022-02-23/>

2 - <https://www.scientificamerican.com/article/5g-wireless-could-interfere-with-weather-forecasts/>

3 - <https://www.thespacereview.com/article/4550/1>

4 - <https://www.ntia.gov/issues/national-spectrum-strategy/spectrum-strategy-pillars/pillar-four>



SpectrumX - An NSF Spectrum Innovation Center



27 Member Institutions	66 Researchers and Staff
20 Collaborating Organizations	109 Students
8 Working Groups	14 External Advisors

As of January 2026

- 5-year, \$25M award from the NSF Spectrum Innovation Initiative (SII), launched September 2021
- Part of unique partnership among NTIA, FCC, & NSF
- Pursuing sustainability with additional \$3.6M from current Industry & Government Collaborations



SpectrumX Government Observers



Derek Khlopin
(NTIA)



Paul Ransom
(NTIA)



Ira Keltz
(FCC)

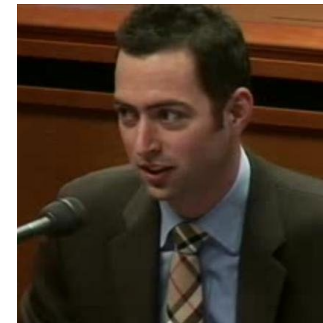

Martin Doczkat
(FCC)



Jonathan
Williams
(NSF)



SpectrumX External Advisory Board (EAB)



Susan Avery



Austin Bonner



Karen Clothier



Maura Corbett



Shelly Frank



Gina Keeney



Julius Knapp



Steve Lang



Ruth Milkman
Vice Chair



Charla Rath



Veena Rawat



Dennis Roberson
Chair

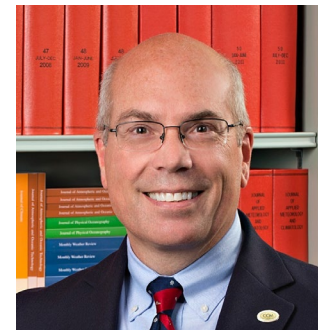

Keith Seitter



William Webb



Center Mission Statement

In order to raise public awareness and maximize the societal benefits of the radio spectrum, ***SpectrumX***

- serves as an inclusive, interdisciplinary, and innovative ***community for all radio spectrum stakeholders*** across industry, government agencies, and academia
- leads ***convergence research*, education and workforce development, collaboration, and policy outreach*** for dynamic and agile spectrum utilization and ensuring innovation and security for all users

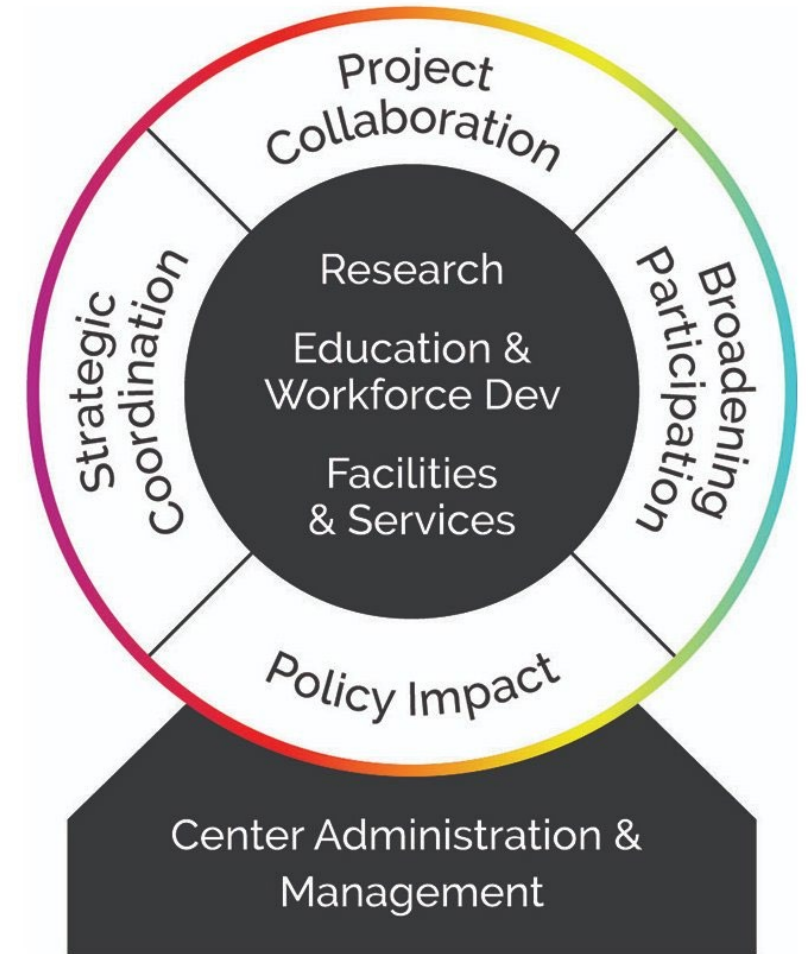

Convergence Research is an NSF term for solving vexing research problems, especially those focusing on societal needs, driven by a specific and compelling problem and showing deep integration across disciplines.



SPECTRUM

Academic Hub in the Radio Spectrum Ecosystem

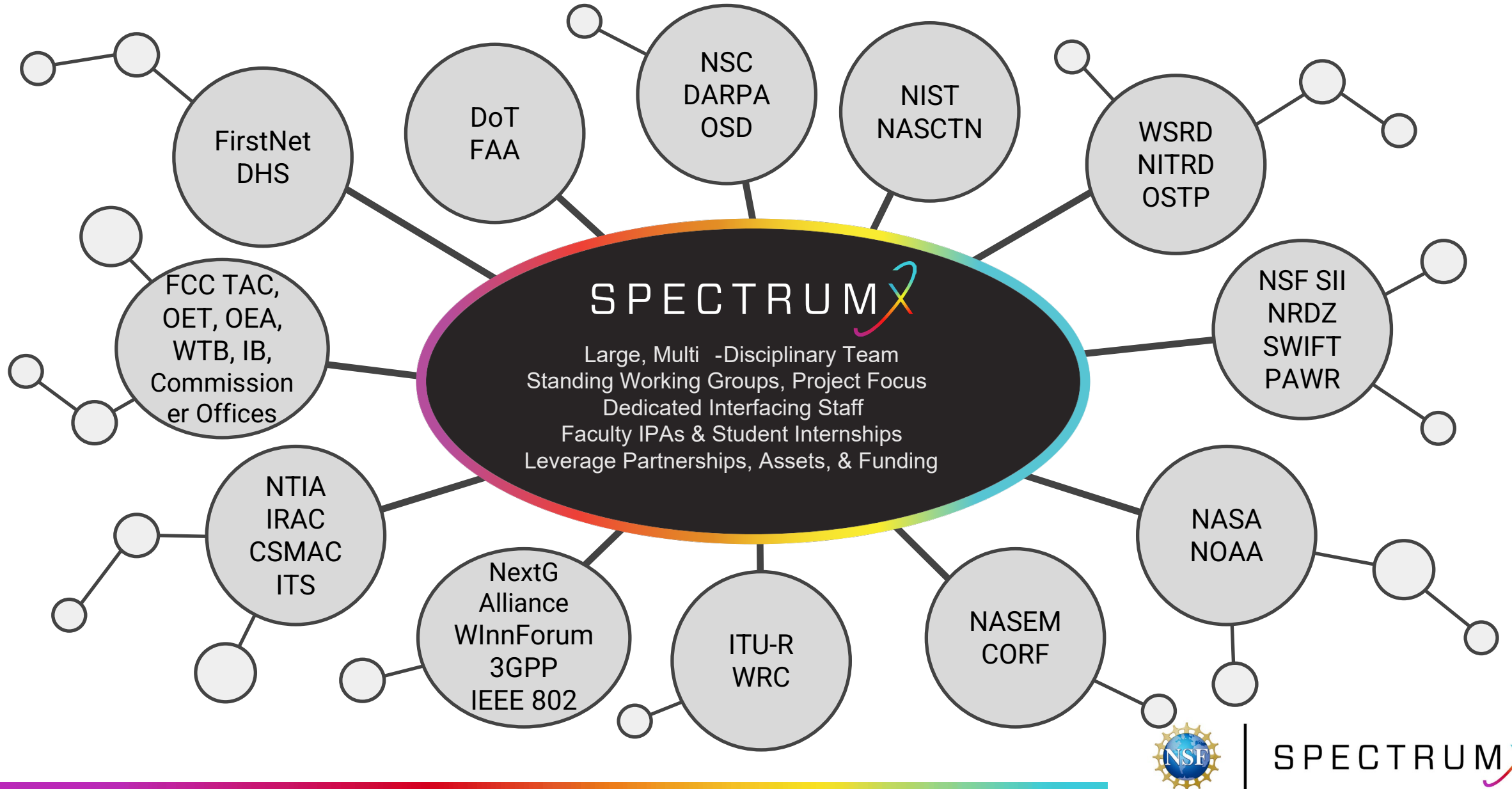

SpectrumX Center Research

Flagship Projects

Large and highly coordinated multidisciplinary efforts to address key spectrum challenges.

2 flagships
33+ researchers

Research Communities

Thematically focused communities for sharing spectrum research.

3 communities
301+ publications

Seed Projects

Small funded efforts to seed novel spectrum research.

4 rounds
17 projects

Liaison Projects

Focused projects with external stakeholders.

7 projects with
NTIA OSM and
ITS.



Spectrum X Center Research

2

Flagship
Projects

33+

Researchers
Engaged in
Flagships

45+

Graduate
Students

17

Flagship
Research
Memos

8

Public GitHub
Repositories

12

Mobile
Experiment
Platforms

2

Spectrum Data
System Sites

RC - Economics,
Rights, & Policy

RC - Technology &
Measurements

RC - Models,
Algorithms, &
AI/ML

Research
Communities (RC)

FP1 - Spectrum
Awareness

FP2 - Scientific
Coexistence

Flagship Projects
(FP)



SPECTRUM X

Spectrum Awareness For Coexistence (“Flagship 1”)

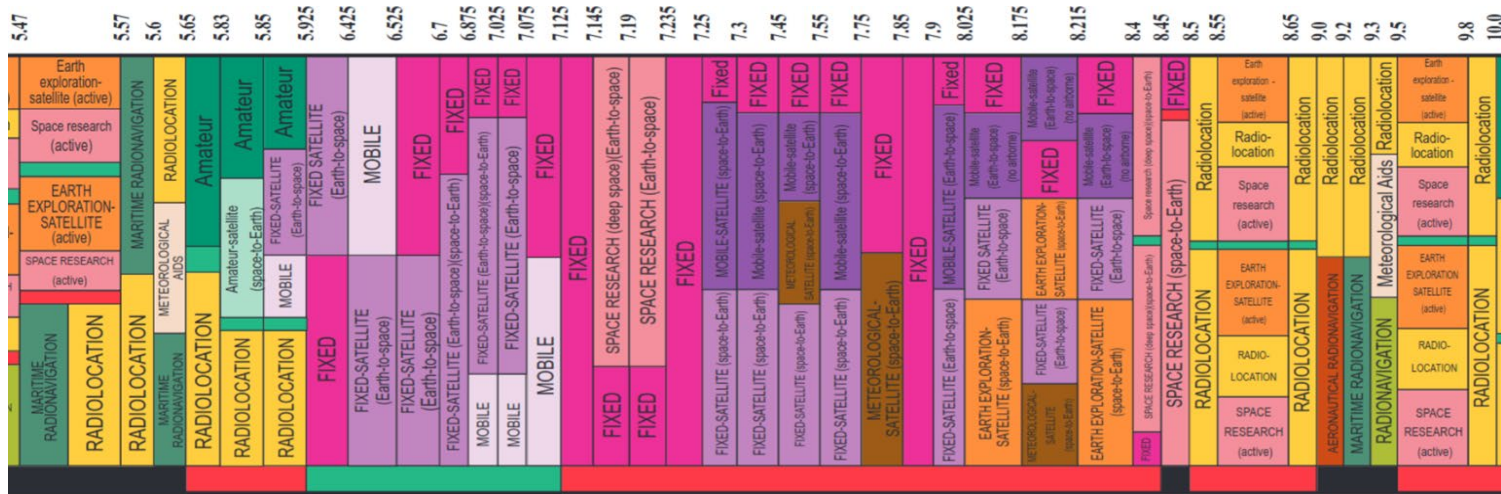

Focus on lower 7 GHz band, per H.R. 1 - OBBBA

Exploring coexistence with NASA & NOAA satcom and radio astronomy

Experiments at 7.125 to 7.145 GHz

Create a “Demonstration of the Possible” for Coexistence by Combining

- Sensing, Models, AI / ML, and Visualization
- Training and Field Experiments
- Exploration of Coexistence Scenarios
- Development of Concepts, Capabilities, and Infrastructure
- Collaboration with Public and Private Sector Partners

Unique Student Experiences

Focused Measurements

Active and Passive Coexistence



Spectrum Awareness Core Efforts

Sensing, Measurement, and Algorithms

- Mobile Experiment Platform (DC to 8+ GHz)
- AI/ML Metadata At The Edge
- RadioHound-X
 - High Integration Open Sensor Platform
 - Low Cost 18 GHz Analog Front End (ASIC)
- Adaptive TX Array Demonstrator (7 to 8 GHz)



Modeling, Rights, and Policy

- Policy Relevant Analysis and Reports
 - Next Generation Wireless in 7 to 8.4 GHz
 - Coexistence Beacons and Waveforms
 - Dynamic Resource Allocation Methods
- Test Approaches in Field Experiments
- Explore Novel Policy and Rights Approaches

Experiments, Demonstrations, and Analysis

- Training Workshops
 - Students build and use Mobile Experiment Platform
 - Workforce Training in Field Experimentation
- Flagship Experiments
 - POWDER Coexistence Waveform Experiments
 - VLA Coexistence Field Experiment
 - Student Data Competition
 - 7 to 8 GHz Satcom Coexistence Evaluation



Data Infrastructure and Interfaces

- Spectrum Data System
- Spectrum Sensor Platform
- Spectrum Data Visualization (for our experiments)
- Data and Metadata Specification

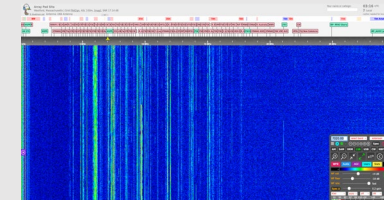

FP1 - Spectrum Awareness Timeline

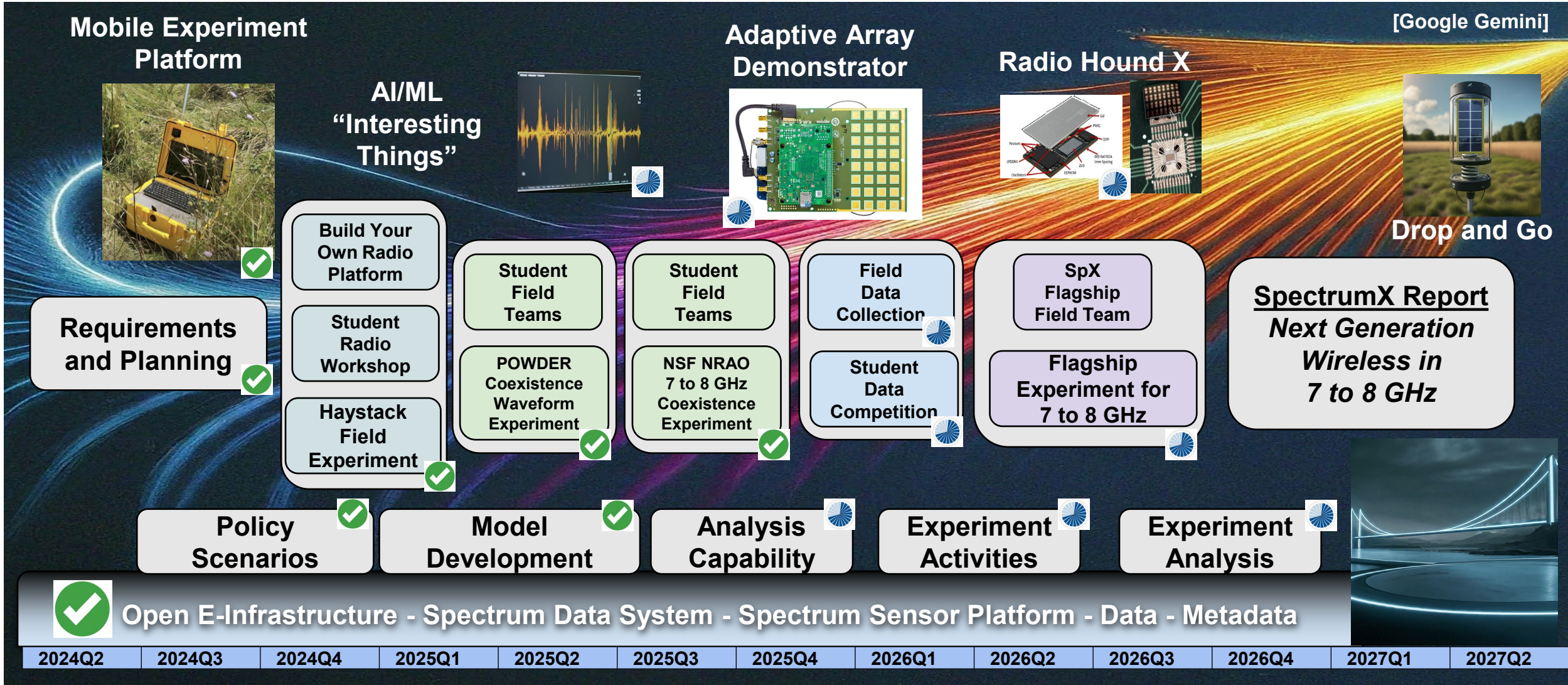

The Mobile Experiment Platform (MEP)

Radios for Radio and Spectrum Science



Advanced radios are critical to effective spectrum field research:

- Portable, usable outdoors, and high performance
- An open source and adaptable platform for spectrum experiments
- Delivering reliable results and engaging students in the design, implementation, and use of the platform

- ✓ Twelve units constructed from November 2024 to June 2025
- ✓ Designs on GitHub (partial now, more in early of 2026, licensing TBD)



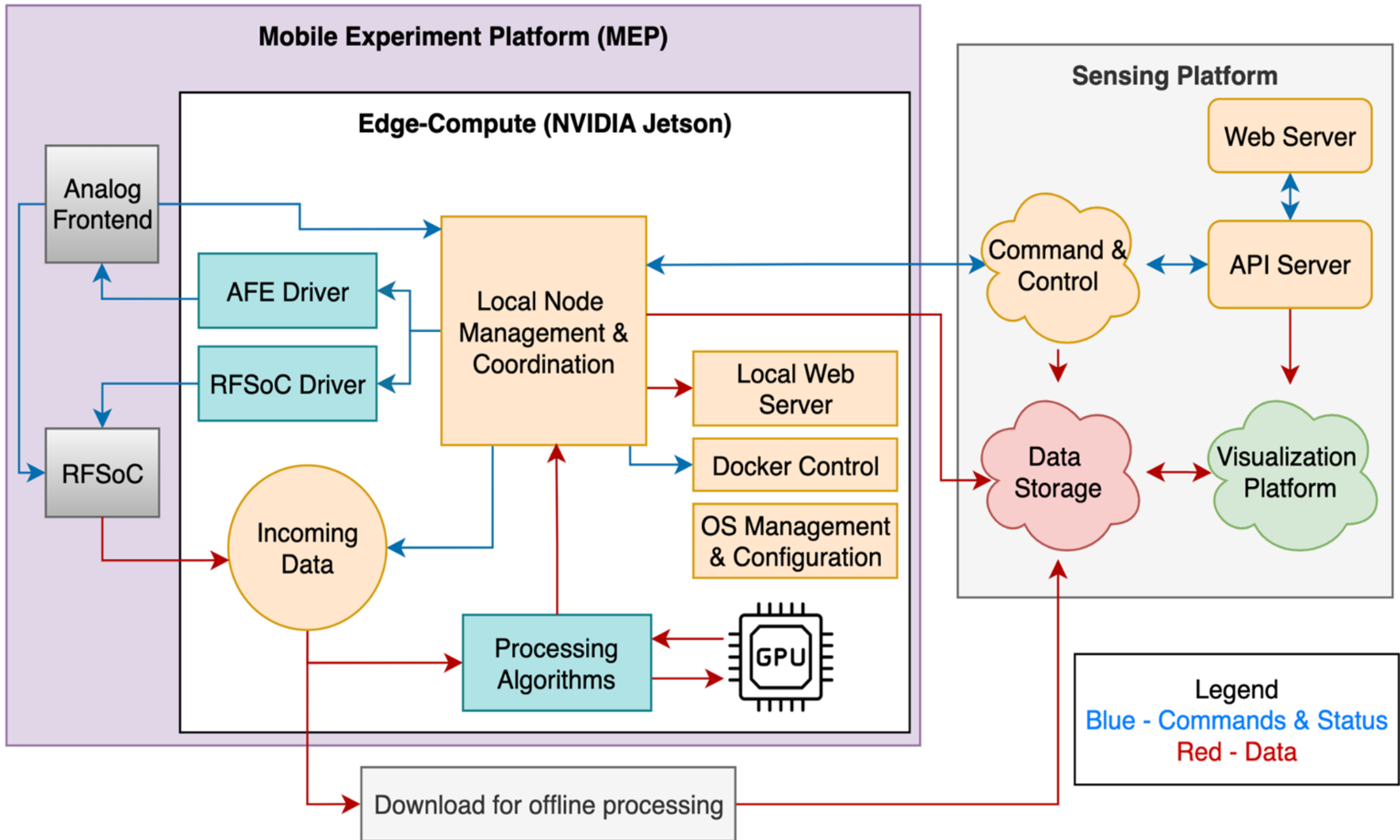

Spectrum Research at NRAO's Very Large Array (VLA)

Policy -Inspired Field Experiments in Central New Mexico in July 6 -11, 2025



VLA team included 24 researchers (students, faculty and partners) from SpectrumX universities, as well as NTIA, NRAO and MITRE



Overview of VLA Field Experiments



VLA Experiment - July 2025

Mobile Experiment Platform Data (Unit 008 / On vehicle with Transmitter)

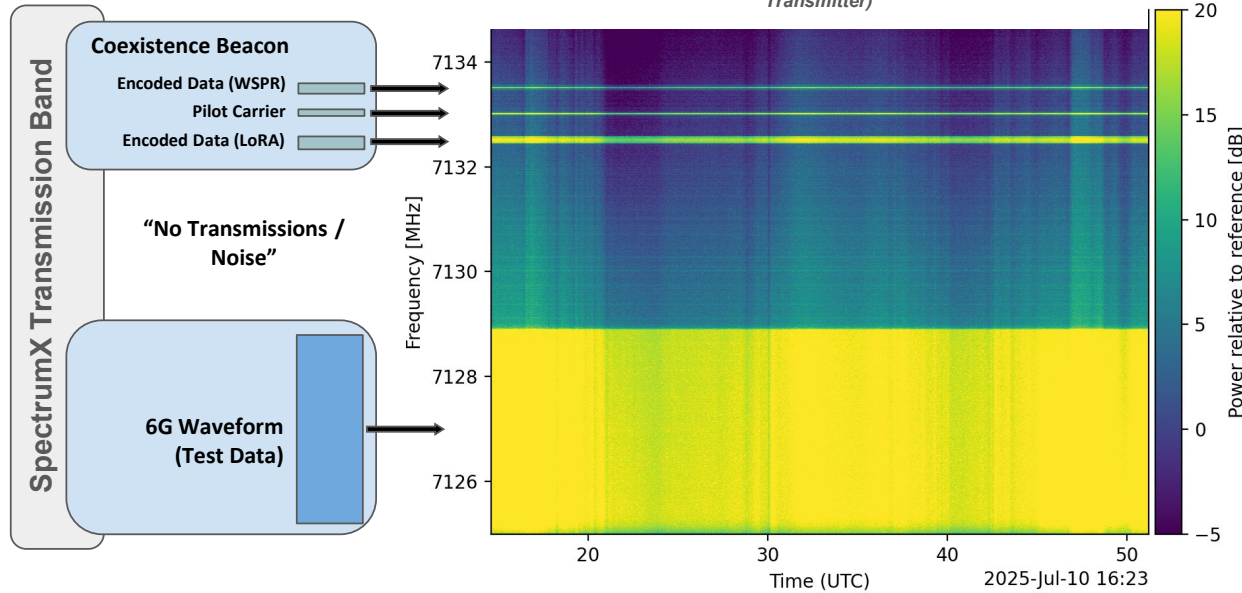

Objectives:

- Characterize lower 7 GHz Regional RFI and Propagation Environment near VLA
- Emulate future lower 7 GHz Mobile Device Emissions
- Test “Coexistence” Beacons for Low Signal-to-Noise Ratio (SNR) Detection of Transmissions
- Engage Students in Policy-Relevant Field Experiments

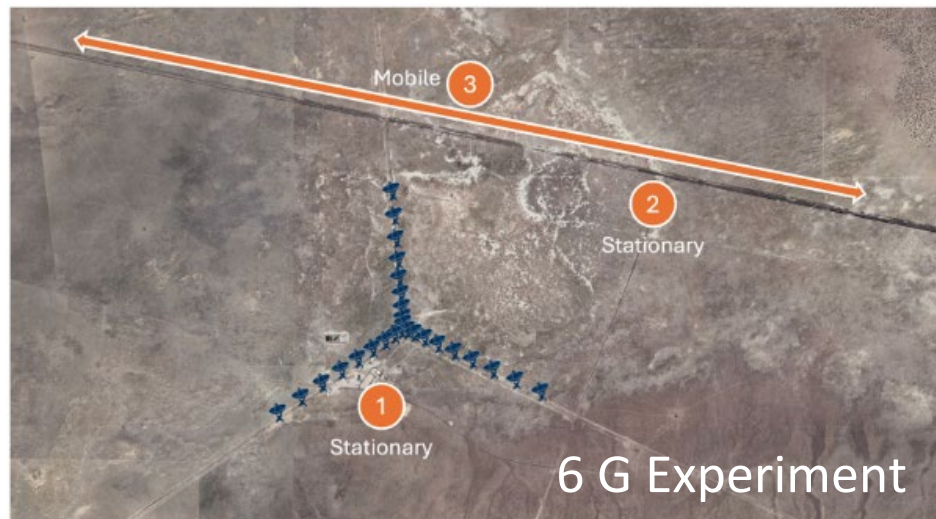

Flagship 2 : Scientific Coexistence and the High Frontier

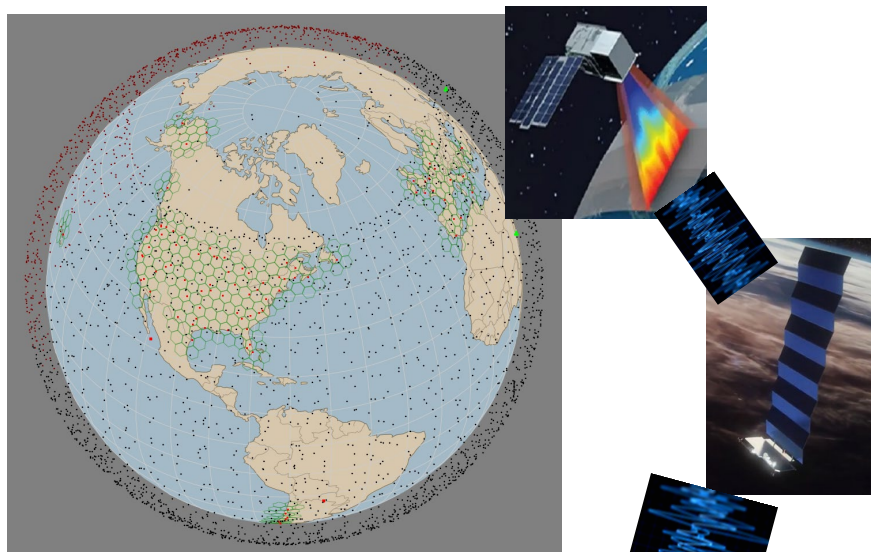

Critical Weather, Climate, and Scientific Systems

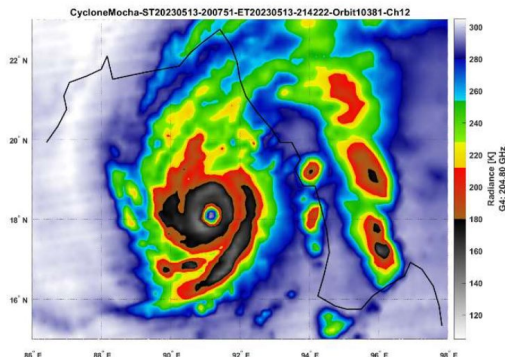

Mega Constellations

Coexistence Methods and Tools

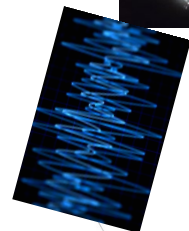

Astronomy Coexistence

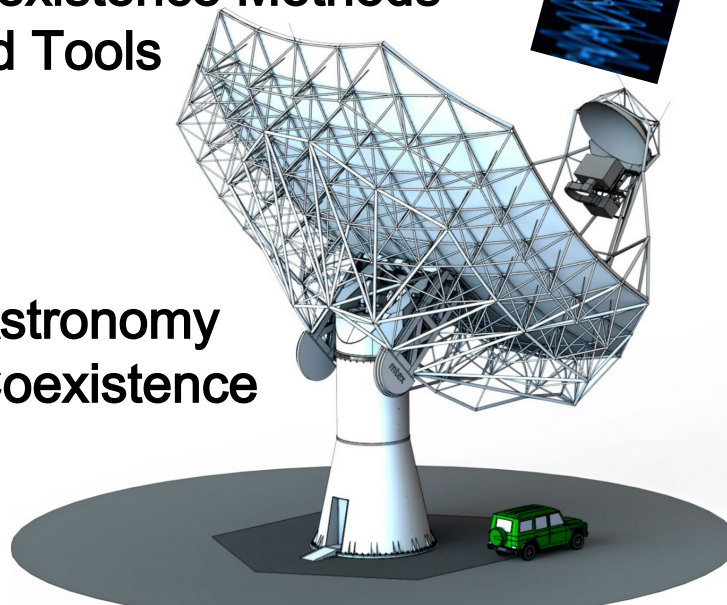

Very Sensitive Systems
Highly Visible RFI (looking up and down)

Lack of Prediction Capability
Inadequate Rights and Coexistence Mechanisms
Unknown Impacts on Systems and Weather Models

The Scale of the Systems Involves Matters
We Need to Look at both Benefits and Challenges

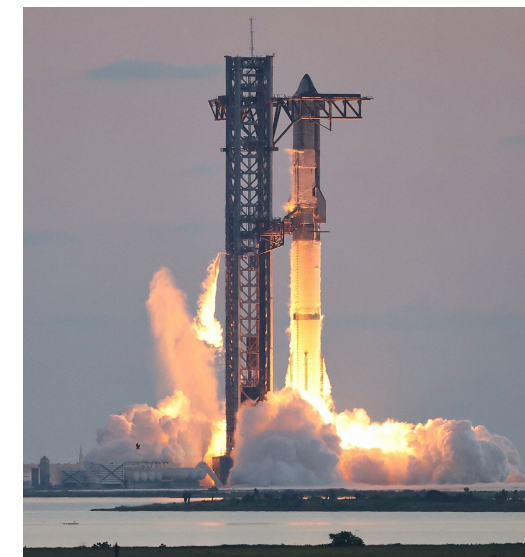

Flagship 2 - Timely and Relevant

FCC Looks to Unleash More Spectrum for Satellite Spectrum Abundance

Full Title: FCC Kickstarts a Proceeding that Could Unlock More than 20,000 Megahertz of Spectrum for High-Speed Internet Delivered from Space
Document Type: Notice of Proposed Rulemaking
Bureau(s): Space
Description: The Commission seeks comment on expanding satellite connectivity across four spectrum bands: 12.7-13.25 GHz, 42.0-42.5 GHz, 51.4-52.4 GHz, and the so-called "W-band" at 92.0-94.0 GHz, 94.1-100 GHz, 102.0-109.5 GHz, and 111.8-114.25 GHz.
DA/FCC #: FCC-25-29
Docket No: 25-180, 22-352, 23-158, 14-177
FCC Record Citation: 40 FCC Rcd 3794 (4)
FCC Record: [FCC-25-29A1_Rcd.pdf](#)

Document Dates

Released On: May 27, 2025
 Adopted Date: May 22, 2025
 Issued On: May 27, 2025
 Comment Date: Jul 28, 2025
 Reply Comment Date: Aug 26, 2025

Related Content

- May 2025 Open Commission Meeting

Files

FCC to Review Spectrum Sharing Rules to Unleash Space Innovation

Full Title: FCC Begins Review of Decades-Old Spectrum Sharing Rules to Unleash the Power of Space Innovation
Document Type: Notice of Proposed Rulemaking
Bureau(s): Space
Description: Notice of Proposed Rulemaking to initiate a review of the decades-old spectrum sharing regime between GSO and NGSO systems operating in the 10.7-12.7, 17.3-18.6, and 19.7-20.2 GHz bands in which equivalent power-flux density (EPFD) limits apply.
DA/FCC #: FCC-25-23
Docket No: 25-157
FCC Record Citation: 40 FCC Rcd 3389 (4)
FCC Record: [FCC-25-23A1_Rcd.pdf](#)

Document Dates

Released On: Apr 29, 2025
 Adopted Date: Apr 28, 2025
 Issued On: Apr 29, 2025
 Comment Date: Jul 28, 2025
 Reply Comment Date: Aug 27, 2025
 Contact: Fatimah.Brown

Related Content

- April 2025 Open Commission Meeting

Files

- **What incentives are needed for scientific coexistence?**
- **How can we coexist with minimum regulation?**
- **What can be done about impacts already at scale?**

Aggregate effects are complex and not easy to mitigate....



Model Prediction of the Starlink Signals Observable by Westford (Includes sidelobes)

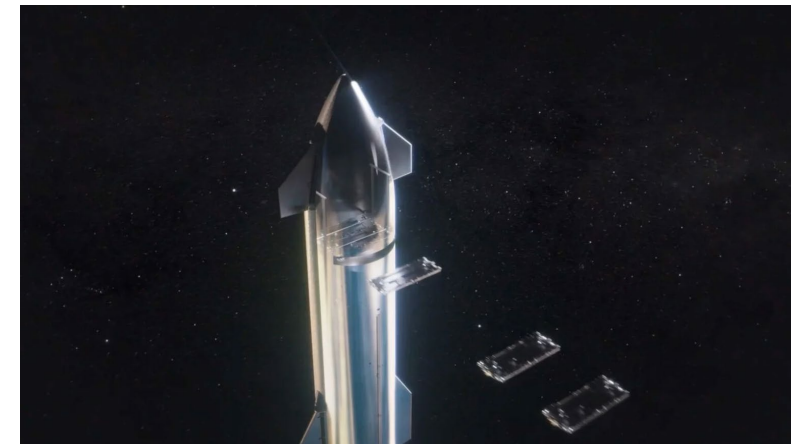
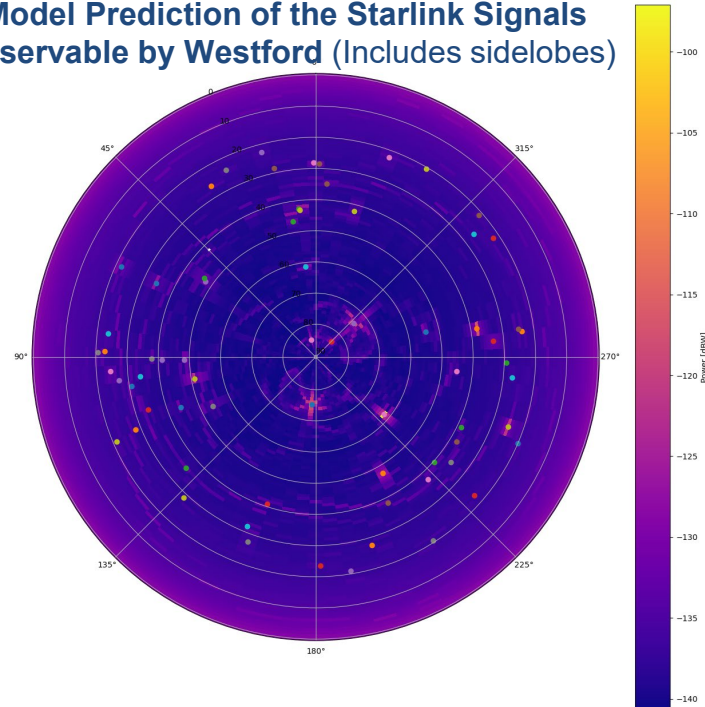

The Falcon 9 deployments are just teasers for the real deal...



Research Communities (RCs)

RC - Economics,
Rights, & Policy



Access rights, comparative analyses,
incentives and mechanisms, empirical
studies, research policy relevance

RC - Technology &
Measurements



Devices, sensors, interfaces,
data collection / storage / curation

RC - Models,
Algorithms,
& AI/ML



Propagation, Spectrum characterization,
Interference modeling and mitigation,
Dynamic resource allocation

- Regular meetings to share ideas and present ongoing research
- Intended to develop project proposals within and outside the center
- Briefings on policy activities
- Entry point for new affiliates (academic, industry, government)
- Communities/themes will evolve.



NTIA OSM & ITS Liaisons



Randy Berry – NWU
Paul Ransom – NTIA
Value Based Spectrum
Management



Cong Shen – UVA
Alan Rosner – NTIA
AI/ML for Spectrum
Management



Monish Ghosh – ND
Nick LaSorte – NTIA
5G Sharing



Nick Laneman – ND
Chris Anderson – NTIA
Education & Workforce
Development, DSS Testbed



Jon Chisum – ND
Charles Dietlein – NTIA
Spectrum Cartography



Kobus Van der Merwe – Utah
Daniel Galanos – NTIA
Table Mountain Open ZMS



Lisa LeFevre – NJC
Adam Hicks – NTIA
Tropospheric Propagation



Education & Workforce Activities

- Grade 6-12 Lesson Plans
- Courseware for Higher Education
- Multi-Institution Summer School
- Enhanced Research Experiences for Undergraduates
- Citizen Science Project



sharemy
lesson

NOTRE DAME
LEARNING

coursera



20
Grade 6 -12
Lessons
Published

1,122
K-12
Students
Engaged

58
REU(+)
Projects

3
Higher -Ed
Courses in
Development

3
Summer
School Sites

75
Citizen
Science Kits
Distributed

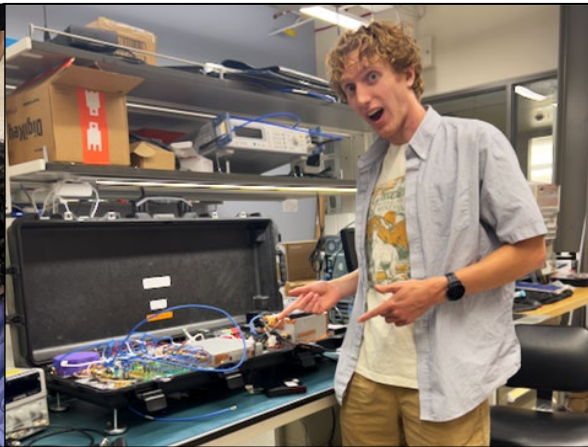
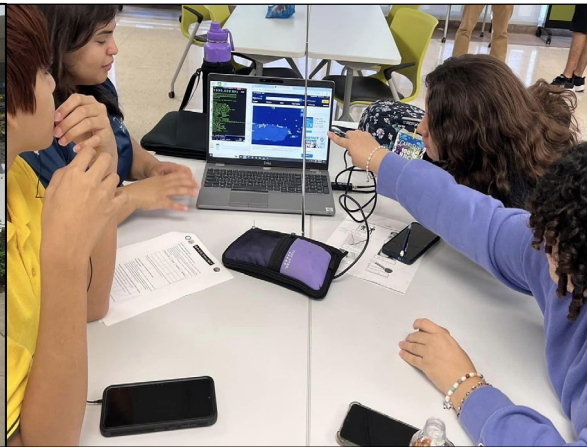

SPECTRUM

The SpectrumX Student Data Competition

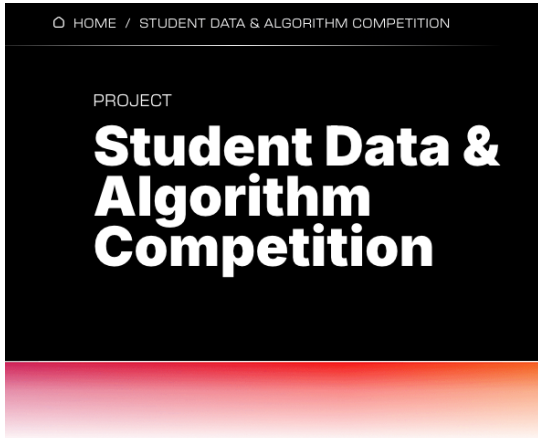

AI / ML Data Labeling for the Very Large Array Experiment

COMPETITION FLOW

- Team registration – December 15, 2025
 - Background materials on data format will be provided
- Data release – December 19, 2025
 - Teams will receive a labeled dataset with known incumbent user activity
- Algorithm submission and evaluation – February 27, 2026
 - Teams will submit their implemented algorithms, including low-level design documents
 - Algorithms will be tested against several unreleased datasets to assess their performance
 - Submissions will be scored based on the specified evaluation metrics
- Results and recognition – Spring 2026 SpectrumX Center Meeting (~April 2026)

Data release types and counts

Case	Subcase	% 1-second samples	Number of 1-second samples
TX	High SNR	20	40
	Mid SNR	20	40
	Low SNR	20	40
	Extremely-low SNR		40
No-TX	With amp (MEP 10)	20	40
	No amp (MEP 12)	20	40

SNR cutoffs

SNR category	Mean SNR
High Amplitude	>1.15 and <=2
Med Amplitude	>1.05 and <=1.15
Low Amplitude	>1.03 and <=1.05
Extremely-low	>1 and <=1.02

Open competition of AI/ML techniques to Data Labeling

- Data from the Very Large Array Experiment
- Open Algorithmic Submissions
- Evaluation Criteria (Objective and Subjective)
 - Detection accuracy
 - Implementation efficiency
 - Algorithmic novelty
 - Visualization quality
- Prizes



[Learn More](#)

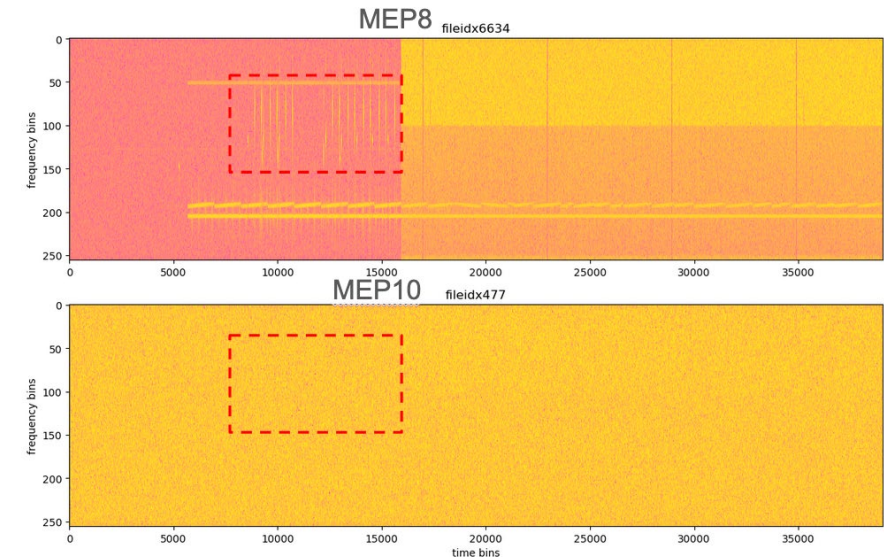

SpectrumX Summer School



Higher -Ed Curriculum Accomplishments

✓ Program Alignment

Radio Systems & Applications

Lead: N. Laneman (ND)

- ✓ Course Alignment
- ✓ Course Outline
- ✓ Course Map
- ✓ All Videos on YouTube Channel
- ✓ 2 Content Modules Finalized in GitHub
- ✓ 1 Content Module Published to Coursera

Spectrum Economics & Policy

Lead: T. Hazlett (Clemson)

- ✓ Course Alignment
- ✓ Course Outline
- ✓ Course Map

Spectrum Management & Policy

Lead: D. Reed (CU)

- ✓ Course Alignment
- ✓ Course Outline
- ✓ Course Map



Higher -Ed Curriculum Development

coursera



NOTRE DAME
LEARNING

*Course: "Point -to -Point
Wireless Telecommunication
Links"*



SPECTRUM 

Coordination & Collaboration Activities

- External Advisory Board (EAB)
- Collaboration Advisory Board (CAB)
- NSF, NTIA, FCC Observers
- Engagement in External Working Groups (NextG, PATHSS, ...)
- Collaboration consultant on board to develop new members
- Collaborate with CAB member for external grant application



Newest CAB Member

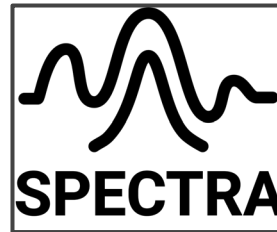

14
EAB
Members

6
Federal Agency
Exchanges

13
CAB
Members

5
Testbed Facility
Exchanges

170+
Convened at
Center Meetings

3
Supplemental
Funded
Programs



Policy Engagement Activities

- Sharing Regulatory Proceedings
- Translating Research Insights into Policy Options and Regulatory Comments
- Prioritizing Policy-Relevant Conferences
- Engaging with Policymakers

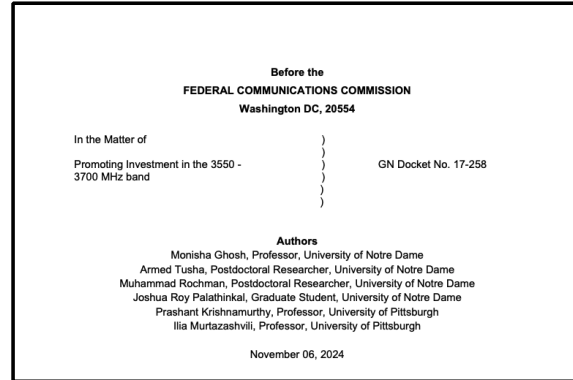
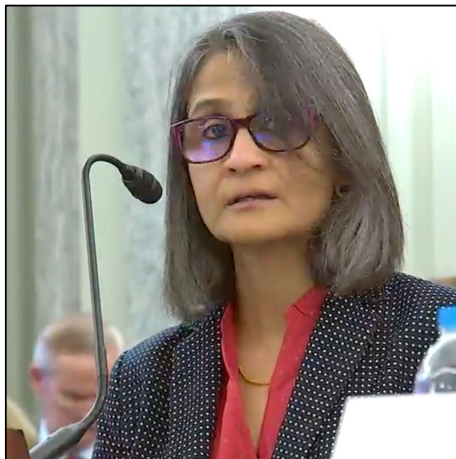

4
 Congressional
 Testimonies

20
 US Regulatory
 Proceedings
 Tracked

~30
 Policy Speaker
 & Panelist Roles

12
 Regulatory
 Comments Filed

> 15
 International
 Consultations
 Tracked

~8
 External
 Engagements



USNC-URSI National Radio Science Meeting



Meetings with Govt Stakeholders



NOAA OSPO
October 2024



Congressional Staffer Meetings
September 2025



Community Engagement

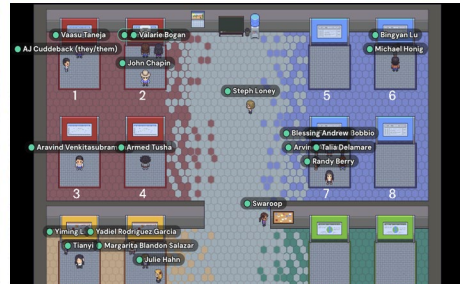
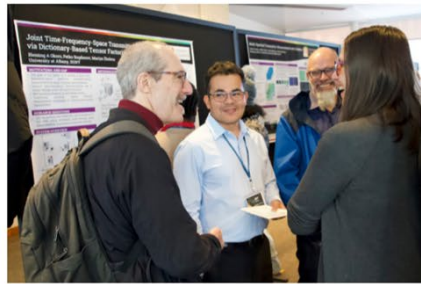

12 papers by
SpectrumX
researchers
and students



- 170+ Attendees, including 80+ Students
- 95+ poster presentations



Learn More and Get Involved



NSF Spectrum Week 2024
450+ Attendees, including 80+ Students

Share Interests &
Contact Info



[www.spectrumx.org/
get-involved/](http://www.spectrumx.org/get-involved/)



SPECTRUM 

Radio Shop Chats

NSF | SPECTRUM

Radio Shop Chat

Views of the National Academies of Sciences, Engineering, and Medicine on Agenda Items at Issue at the World Radiocommunication Conference 2027

Nathaniel Livesey
Senior Research Scientist
Jet Propulsion Laboratory,
California Institute of
Technology

Scott Paine
Senior Physicist
Center for Astrophysics,
Harvard & Smithsonian

Wednesday, August 6 at 3:00 p.m. EDT
Registration Required



Average 50+ participants / chat!
Opening to the entire spectrum
community!!

<https://youtube.com/playlist?list=PLy6Bhtn0G0AbGVpZ3lj3wZr1MJ9ssmVvf&si=p693GVCN1znp-fU3>

Let us know if you have a Radio Shop Chat Speaker Recommendation



SPECTRUM

SpectrumX Impact Report

- Report highlights:
 - Overview of Center's strengths and unique characteristics
 - Outline of major projects and accomplishments organized by Center goals
 - Brief preview of future goals, projects, and potential
 - To be released in May 2026

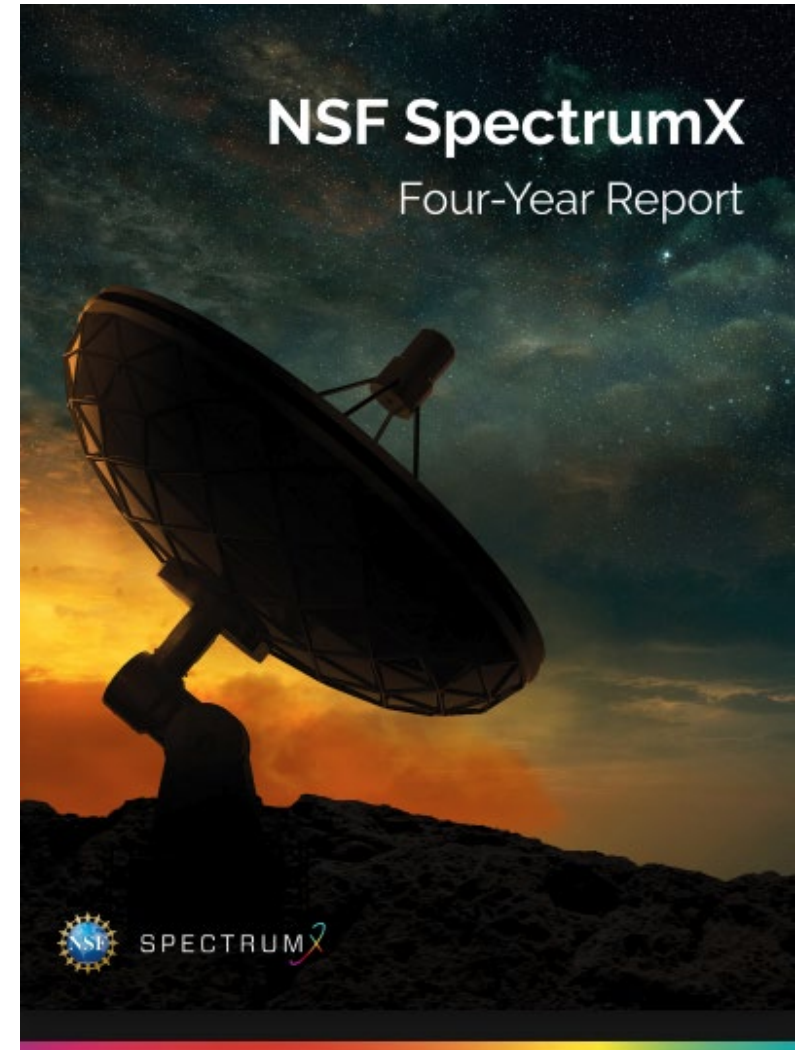

Celebrating Center Successes

BUILDING A COMMUNITY

- 1,417 Unique Participants
 - 66 Researchers & Staff
 - 109 UGs/Grad/Postdoc Students
 - 14 EAB Members
 - 13 CAB Members
 - 1,215 Other Industry, Govt & Academic Participants
- 27 Participating Institutions
- 63 Participating Partners

NEW FUNDING TO SUPPORT GROWTH

- Broadband MAPUS with Partner Institutions (NSF and Google)
- SII-GRS Fellows (NSF)
- Student REU & Travel Grants (NSF)
- NTIA OSM Liaisons (NTIA)
- NTIA ITS Liaison (NSF)
- Postdoc (NSF SII -NRDZ -SBE)
- CAB Membership Fees (Industry)
- Conference and Meeting Supplements (NSF & NTIA)

LEADERSHIP AND CONVENER

- 9 Center Meetings
- 9 EAB Meetings
- 27 Radio Shop Chats
- NSF Spectrum Week, NTIA Listening Session, & Hi-Band SDR Workshop
- 2,300+ Followers on Social Media

MAKING AN IMPACT (THRU Y5Q1)

- 97 Journal Publications
- 200+ Conference Papers & Other Publications
- 20% of IEEE DySPAN 2025 papers were authored by SX researchers
- Over 10 Formal Regulatory Comments
- Books, Patents, Dissertations, Websites, etc



Backup Slides



Sensing Platform

Goal: Build fully-managed edge-compute software stack and sensing platform to support MEP and enable edge-based AI

- Local web server controls RFSoc, Recorder and SDS uploads
- All services now MQTT native

Node: MEP

Node Details

Periodogram

Waterfall

Heatmap

MEP

Archived Data

Calibration

Admin

Freq (MHz) 97

Tune

Recorder options:

Channel A

Sample Rate 10

Start Stop Clear

SDS Upload options:

Directory /data/ringbuffer/sr1MHz

Reference Name

SDS API Token

Start Time 2025-01-01 00:00:00

End Time 2025-12-31 23:59:59

Upload Randy Test

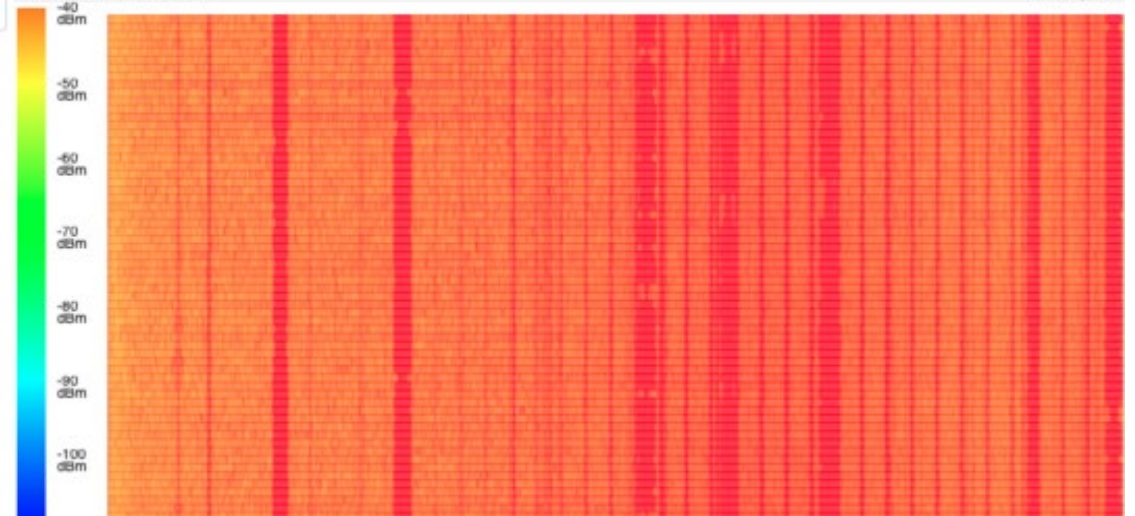
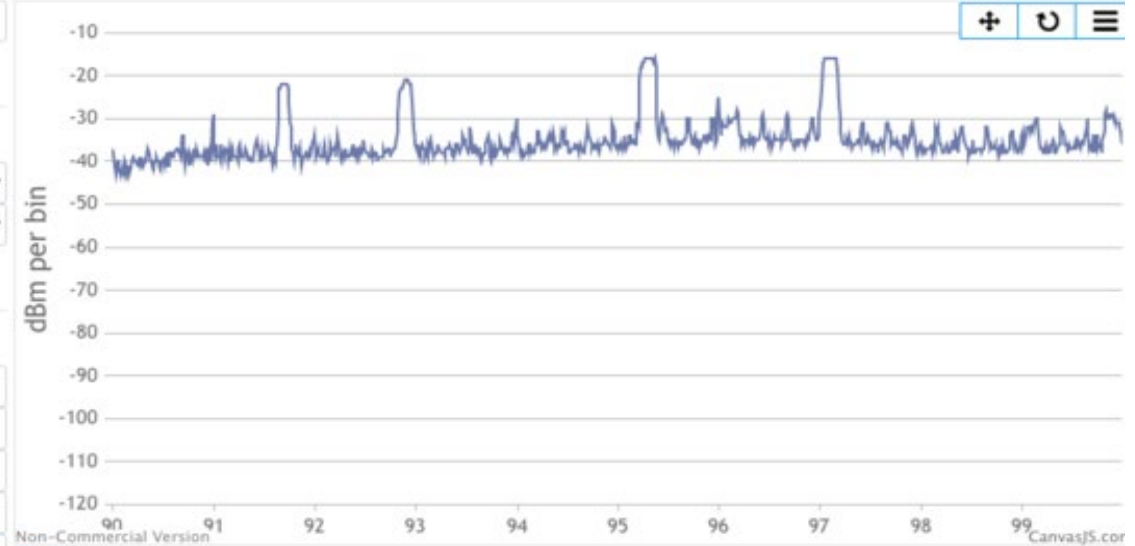

ND: Randy Herban, David Pettifor, Lucas Parzianello, Kinsey Poland

CU: Nick Rainville, John Marino MIT: Ryan Volz



Edge AI/ML

Goal: Developing edge AI/ML algorithms for

1. detecting and characterizing the RF environment
2. processing the metadata
3. identifying the RF signals
4. capturing the emergence of events

Main accomplishments:

1. Metadata processing tools (sensing and targets) for goals 1 and 2
2. DL framework that jointly detect and recognize wideband signal for goal 3
3. Shallow transformer signal detector for goal 3

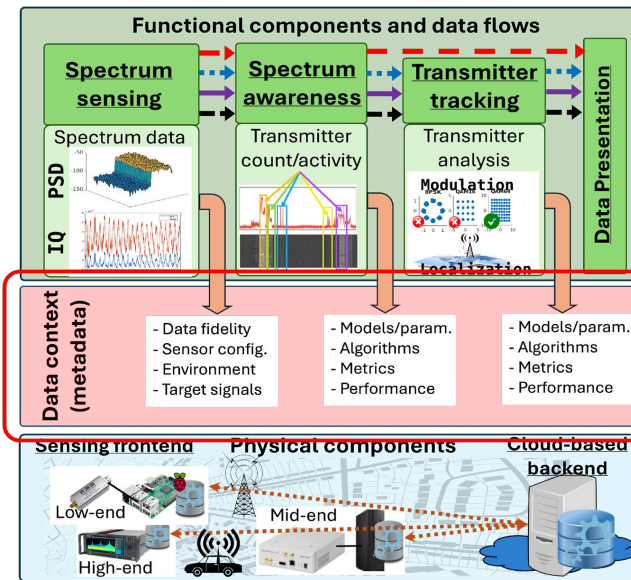
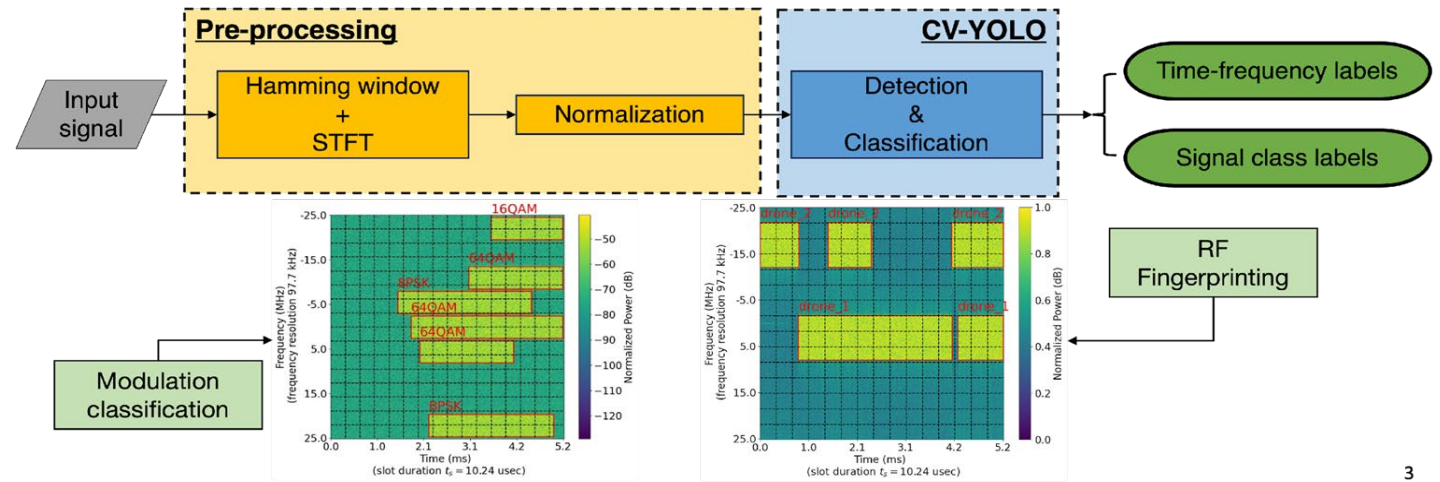

Team: Cong Shen (UVA), Danijela Cabric (UCLA), Mariya Zheleva (Albany), Karyn Doke (Hamilton), Anant Sahai (Berkeley)

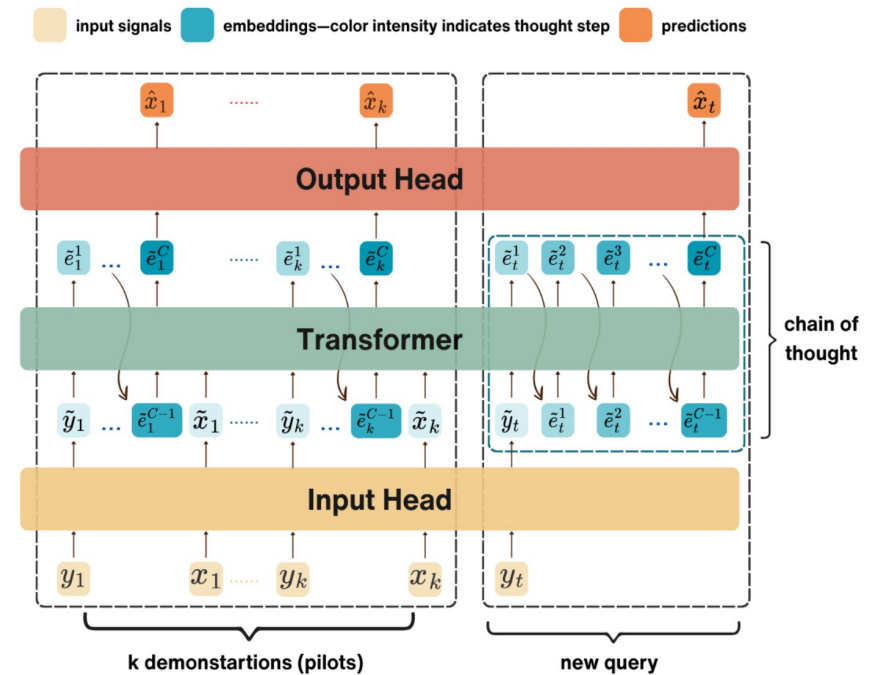

RadioHoundX

Goal: Low SWAP-C sensing via Silicon integration

- *Develop SWAP+ prototype: integrate RF tuner and LO*
- *Identify research problems and funding avenues*

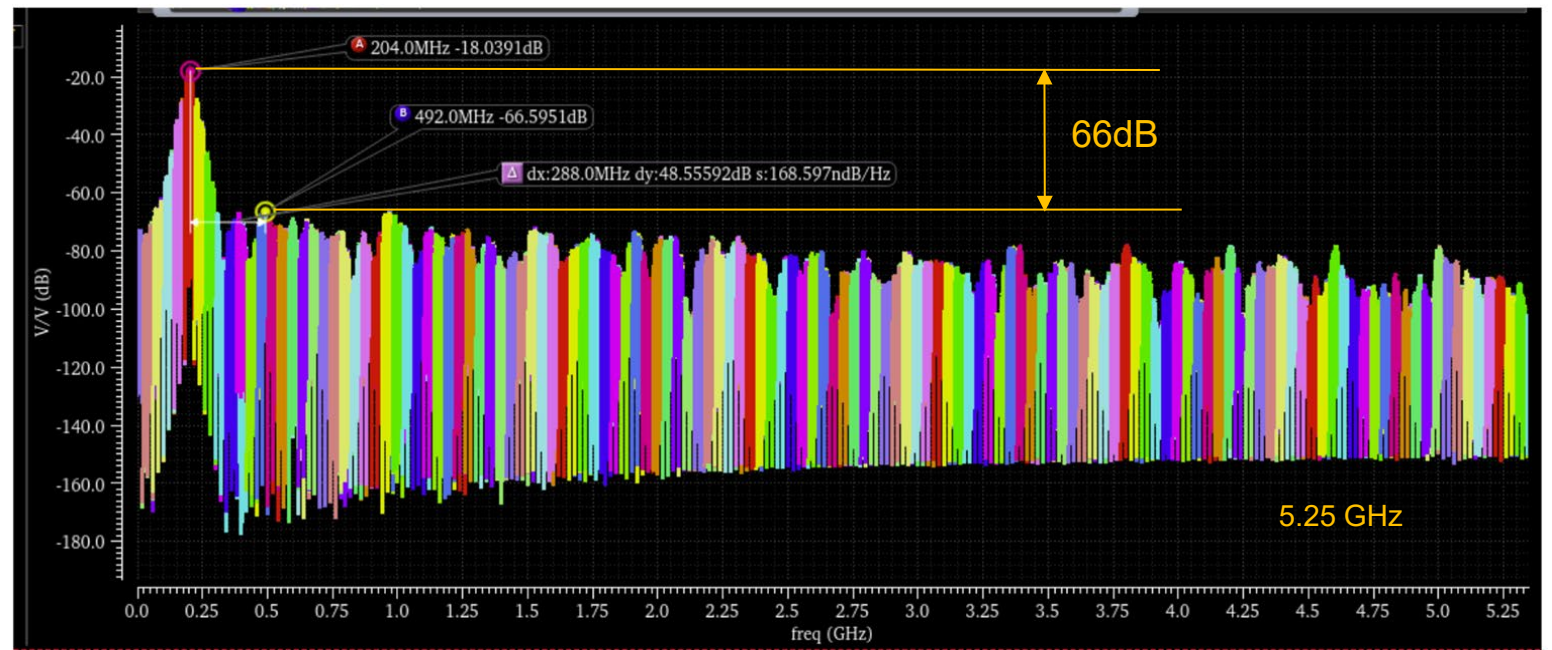

18 GS/s Periodically Time-Varying Circuit, 28nm CMOS.
Sim conditions: 204 MHz LO, 0.8V-1.2V supply.

Recent Achievements:

- *Tuner IC schematic (layout) design 80% (~10%) done*
- *Showed >65dB stop-band (incl. harmonic rejection) in full core circuit sims*
- *Identified approximate analog DFT as a promising research avenue*

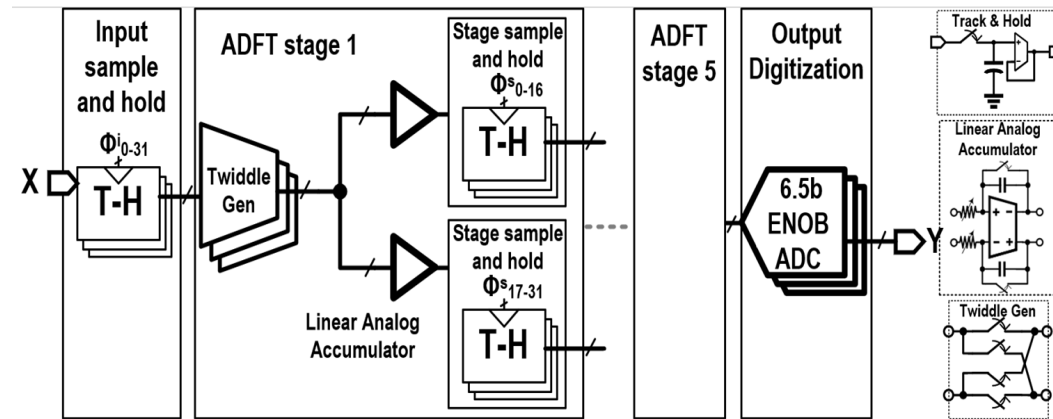

Prelim sims/estimates:

- *256-point DFT,*
- *9b accuracy,*
- *1nJ / frame,*
- *Incl. post ADCs, ~600x lower energy*

Sudhakar Pamarti, UCLA
Arjuna Madanayake, FIU



WE - Phased Array Demo

Portable 16-channel
In-Band Full-Duplex (IBFD)
Digital Beamforming
7-8.4 GHz - 160 MHz IBW

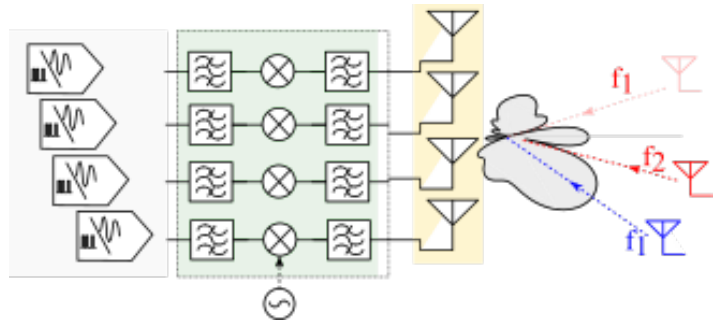

- ✓ Digital BF hardware operating
- ✓ Antenna array prototyped
- ✓ Case and power supply prototyped

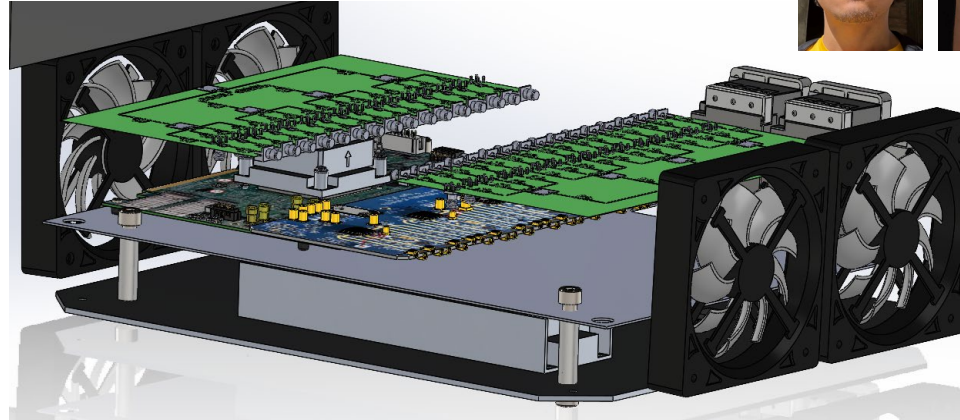

Laila Marzall (UCB), Zoya Popovic (UCB), Taylor Barton (UCB), Rafael Solís (UPRM), Danijela Cabric (UCLA), Ryan Voltz (MIT Haystack)

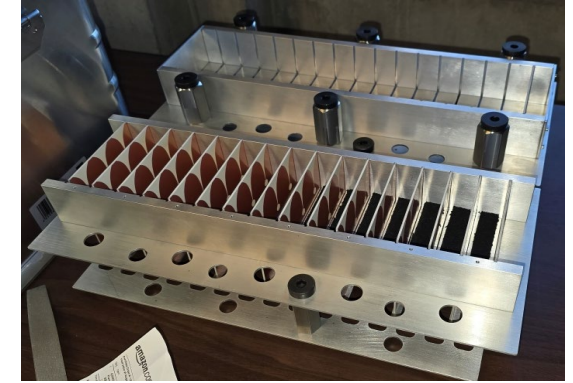

Spectrum X FP2 Highlight - Megaconstellation Modeling and Measurement

Model Prediction of Starlink Signals at Westford with and without Beam Avoidance

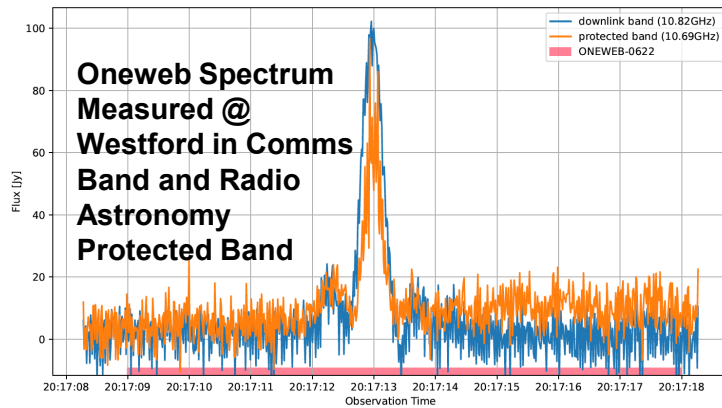

Oneweb Spectrum Measured @ Westford in Comms Band and Radio Astronomy Protected Band



Model Prediction of the Starlink Signals Observable by Westford (Includes sidelobes)

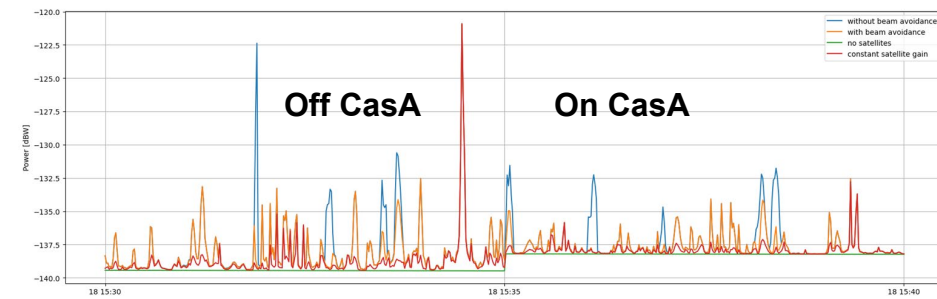
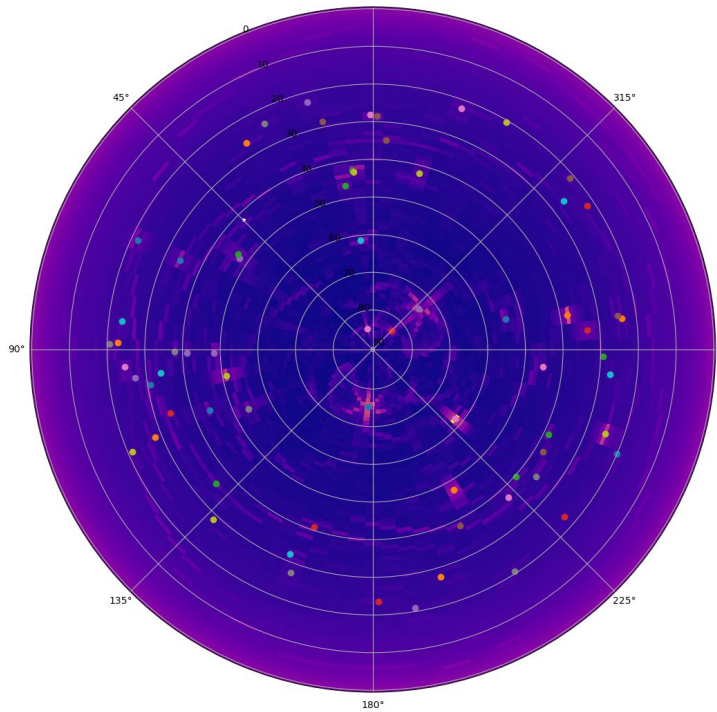

Westford RF Power Measurements In the 10.82 GHz Band (Off and On CasA) This is Just Below the 1st Starlink Channel

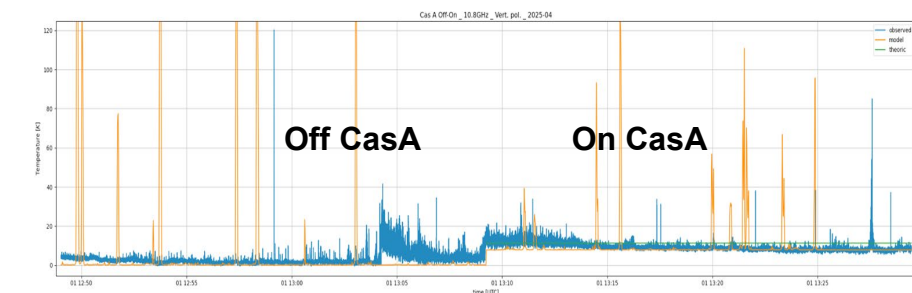

Ettus and RFSoc Data Acquisition 400 MHz to 14 GHz > 14TB Collected IQ to date...

Near Term Focus on Radio Astronomy Protected Bands (L-band, X-band)



Center Goals Statement (5 Years)

1. Create an innovation engine for interdisciplinary, translational, and convergence research* on technologies and policies for the advancement, sharing, and management of the radio spectrum.
2. Attract, engage, and prepare students from middle school through post-graduate levels to pursue meaningful careers in the radio spectrum workforce.
3. Grow professional competencies throughout the Center and broaden participation in all Center programs and activities.
4. Foster unsurpassed coordination, collaboration, and value creation across industry, government, and academic stakeholders.
5. Serve as the go-to, trusted, and equitable resource to transfer knowledge among radio spectrum stakeholders and policymakers, proactively address long-term radio spectrum issues, and help reduce drawn-out radio spectrum conflicts.
6. Grow the Center's visibility and reputation, streamline its operational efficiency and effectiveness, and be a responsible steward of all institutional and partner resources.

Convergence Research is an NSF term for solving vexing research problems, especially those focusing on societal needs, driven by a specific and compelling problem and showing deep integration across disciplines.



Working Groups

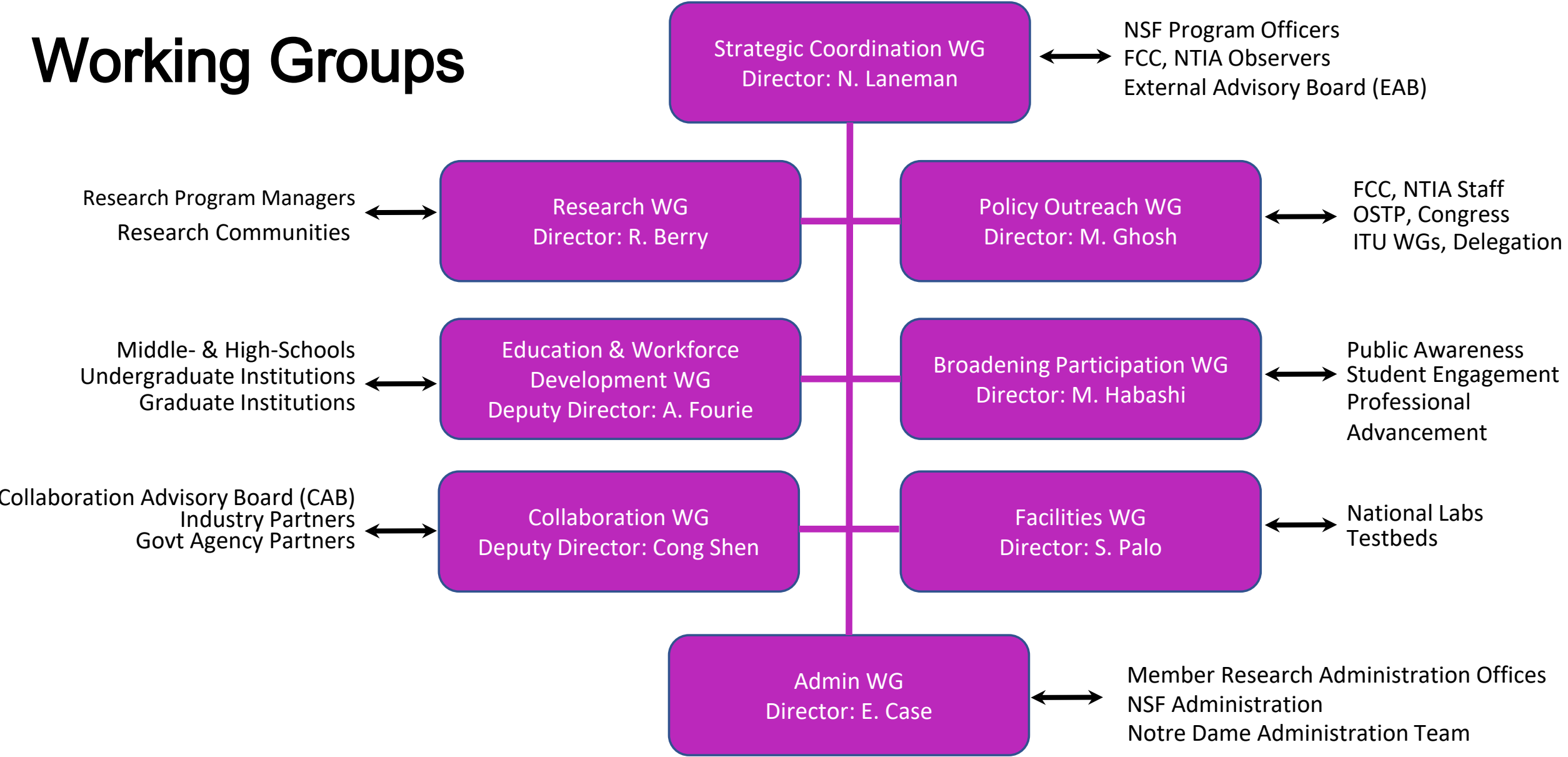

Research Communities (RCs) Highlights

Internal Presentations:

Underlay communications, Non-terrestrial backhaul networks, LLMs for spectrum policy, Federated learning, Radar + comms coexistence, Landscape rights for spectrum, Alternative rights for high-frequency bands, Hyperspectral Sensor and Spectral Kurtosis.

External Speaker Presentations:

Closed-loop spectrum management, NRDZ-as-a-system, Digital twins for spectrum.

DySPAN 25 tutorial:

“SpectrumX toolkit for data-driven spectrum” by AI/ML RC

Publications:

20+ papers at TPRC and IEEE DySPAN on policy related topics
Best paper awards at DySPAN for Policy and Technology.

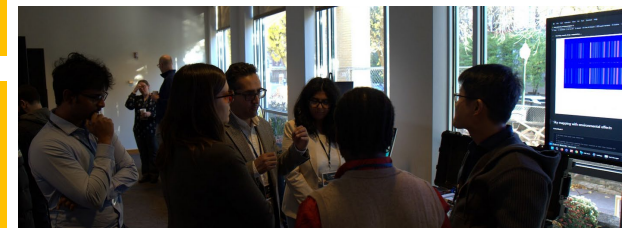
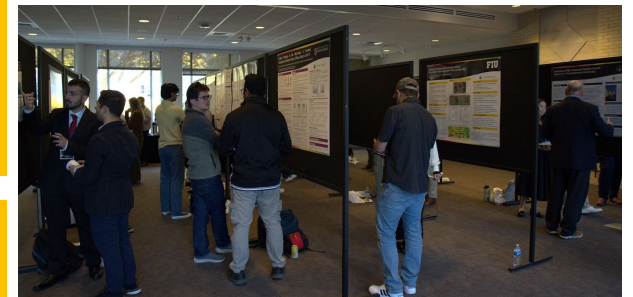
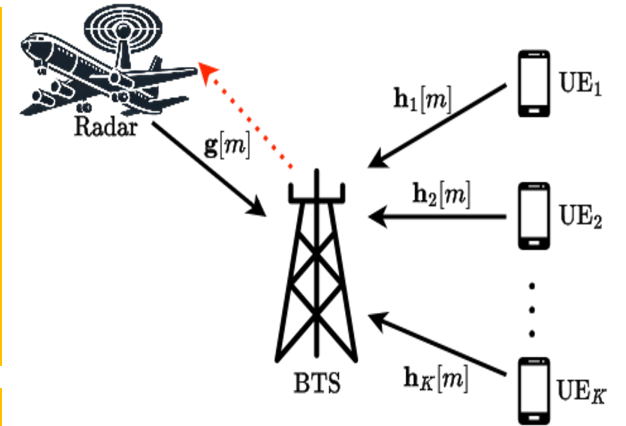

SpectrumX Leadership



Nick Laneman
Center Director
SWG



Anja Fourie
Education & Workforce
Development Deputy Director



Meara Habashi
Broadening Participation
Director



Monisha Ghosh
Policy Outreach
Director

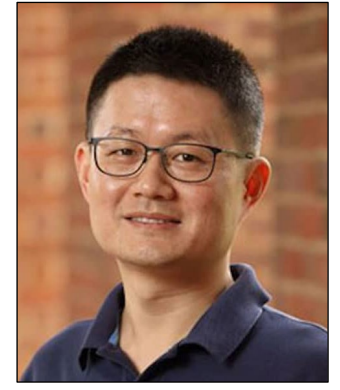

Cong Shen
Collaboration
Deputy Director



Scott Palo
Associate Director
FWG



Emily Case
Administration
Director



Scott Barker
Broadening Participation
Deputy Director



Prashant Krishnamurthy
Policy Outreach
Deputy Director



Bobby Weikle
Steering Committee
Chair



SpectrumX Research Leadership



Randy Berry
Research Director



Frank Lind
Research Deputy
Director



Mary Knapp
FP Project
Manager



Mariya Zheleva
Models, Algorithms,
AI/ML RC



Al Gasiewski
Technology & Measurements RC



Ilia Murtazashvili
Economics, Rights & Policy RC



Facilities & Services Activities

- Launched WG in Jan 2024 (mid year 3)
- Conducted monthly meetings Sep 2024 - Aug 2025
- Building working relationships with the NSF PAWR platforms
 - [POWDER](#) - The nation's first open programmable advanced wireless research testbed
 - [AERPAW](#) - Aerial Experimentation and Research Platform for Advanced Wireless
 - Waveform coexistence experiment (N. Sidiropoulos at POWDER)
 - Deployment of MEP to POWDER
 - Discussion with AERPAW regarding student competitions
- Discussion with NTIA/ITS regarding Dynamic Spectrum Sharing Test Bed
- Collaboration with MITRE regarding NRDZ Sparkie EEL and Hat Creek Observatory experiment
- Presentation on UNM Playas NM facility (Gil Petrina) - discussion about collaboration with SpectrumX
- Continued recurring tag -up coordination meeting with facilities partners to encourage ideation and proposal development



Haystack Observatory



Mobile Experiment Platform (MEP)



Administrative Activities (Goal #6)

- Brand Identify and Management, SW AG
- Communication Channels - Website, LinkedIn, YouTube, Mailing list
- Meeting Planning and Facilitation
- Subaward Management
- Reporting to Sponsors

12,500+

Active
Website
Users

14

Recurring
Meetings
(Biweekly)

2,300+

LinkedIn
Followers

18

Center + EAB
Meetings
Organized

1,200+

Mailing List
Participants

~20

Subawards

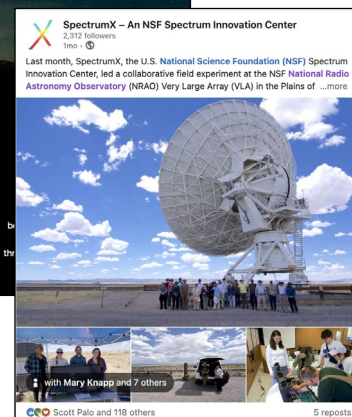
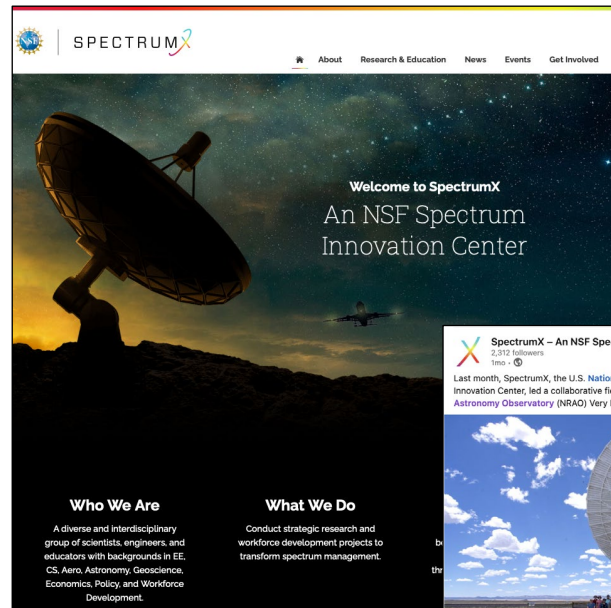

SPECTRUMX

SpectrumX Seed Projects

- Small -to-m oderate, lim ited-term investments to explore a new topic.
- Proposals may be multi-year, but funding is allocated on an annual basis.
- Reviewed by Research Planning Committee.
- Opportunity for advisory boards and stakeholders to suggest and influence projects .

Year 2 & 3

- 6 GHz indoor/outdoor measurement campaign
- New radiometer and 24 GHz measurement campaign
- Diversity in spectrum sharing agreements
- Unobtrusive signal alignment for low power underlays
- True Time -Delay beamforming and the Radon Transform
- Quantifying 5G RFI on spaceborne microwave radiometers
- Towards better interference management: Leveraging signals of opportunity for environment detection

Year 5

- Spectrum Interference Experiment Campaign Using MEPs and Phased Array Demo
- Expanding Analysis of 5G RFI on Spaceborne Microwave Radiometers
- Differentially Private Spectrum Data Synthesis for MEP and Beyond
- The Impact of Future 6G Cellular Networks on Weather Satellite Downlink in the 7 -8 GHz Band

Year 4

- FR3 Agile RF Front Ends with Analog and Propagation Interference Suppression.
- Operator Self -identification for Spectrum Sharing
- Byzantine Fault Tolerance in Spectrum Sharing Regimes
- SpectrumX Chatbot
- Multi -spectral Transmitter Characterization
- Open, Scalable SigCap Data Platform

Highlight = Flagship Integration



Selected Seed Project Outcomes

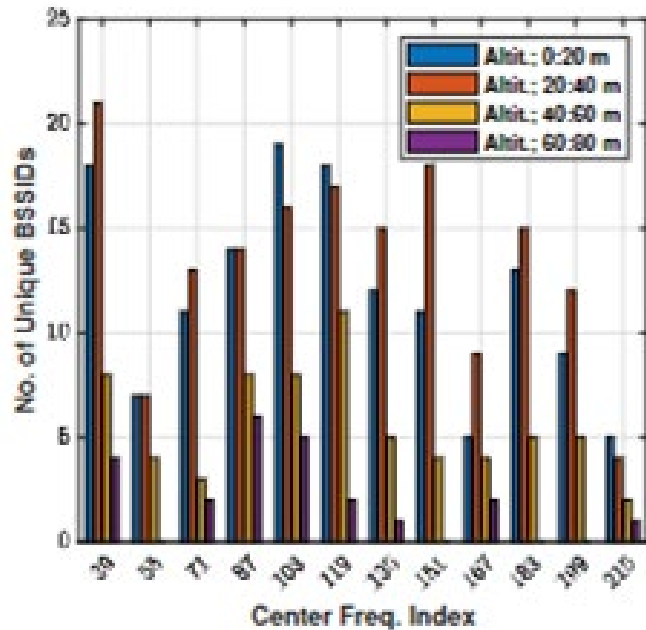

Underlay laboratory experiment

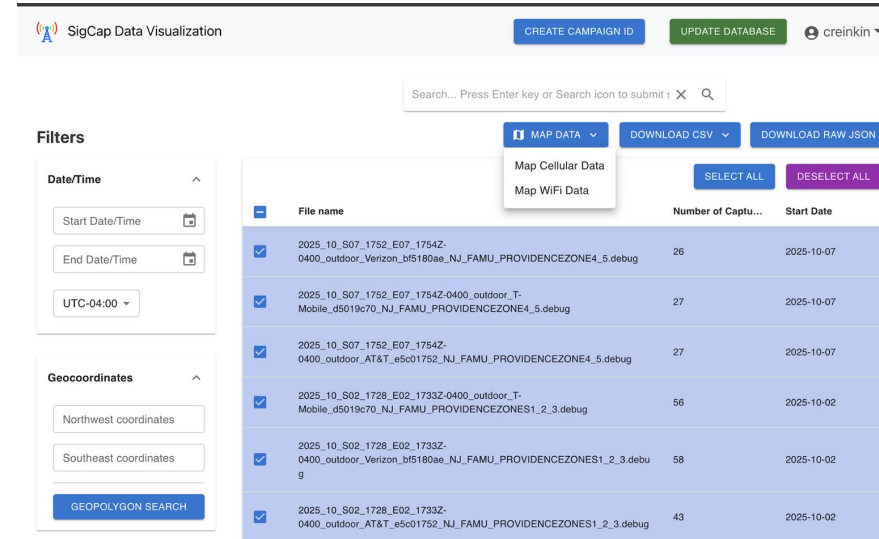

SigCap portal

6 GHz indoor/outdoor measurement campaign

3 papers, 2 FCC comments filed that used these results, one new project funded by INL ; Transitioned into FP1 for inclusion in Year 5 experiments.

Unobtrusive signal alignment for low power underlays

1 journal paper, effort led to a new effort to exploiting diversity in SIGFOX/LORA IoT protocols; work transitioned into FP1.

Open, Scalable SigCap Data Platform

Successfully deployed a web-based SigCap portal for uploading & accessing measurements taken with SigCap app. Future work to include integration into the Spectrum Data System.

Broadening Participation Activities

- Institution & Community Outreach (ASEE By the Numbers, Professional Organizations)
- Professional Skills Assessments & Development
- Research Onboarding



Leadership Development Session
with Jirs Meuris
2025 Fall Center Meeting

Professional Dev Tools

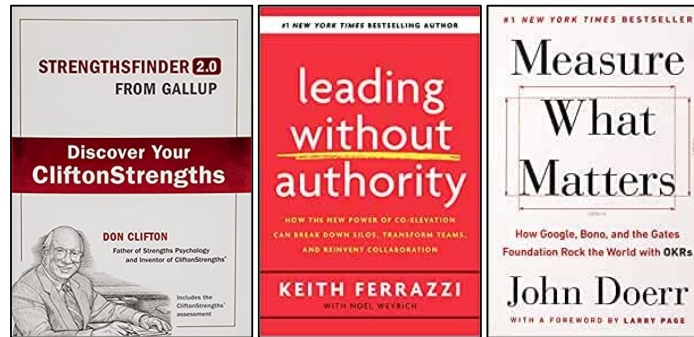

Broadband Mapping US

25

New Affiliates
(since launch)

9

New Subawards
(since launch)

40

Professional
Assessments



Website

- Launched new Spectrum X website in December 2024 with:
 - Website visitors equal 12,700+ with over 41,500 page views in Y4
 - Average engagement time on pages = 59 seconds
 - 13 News Stories
- Website highlights + resources include:
 - PDF lesson plans and video courseware
 - News updates on Center research and initiatives
 - Center-supported publications
 - Congressional testimony and policy comment links
 - Project overviews and updates
 - Calendar with Spectrum X and major spectrum community events

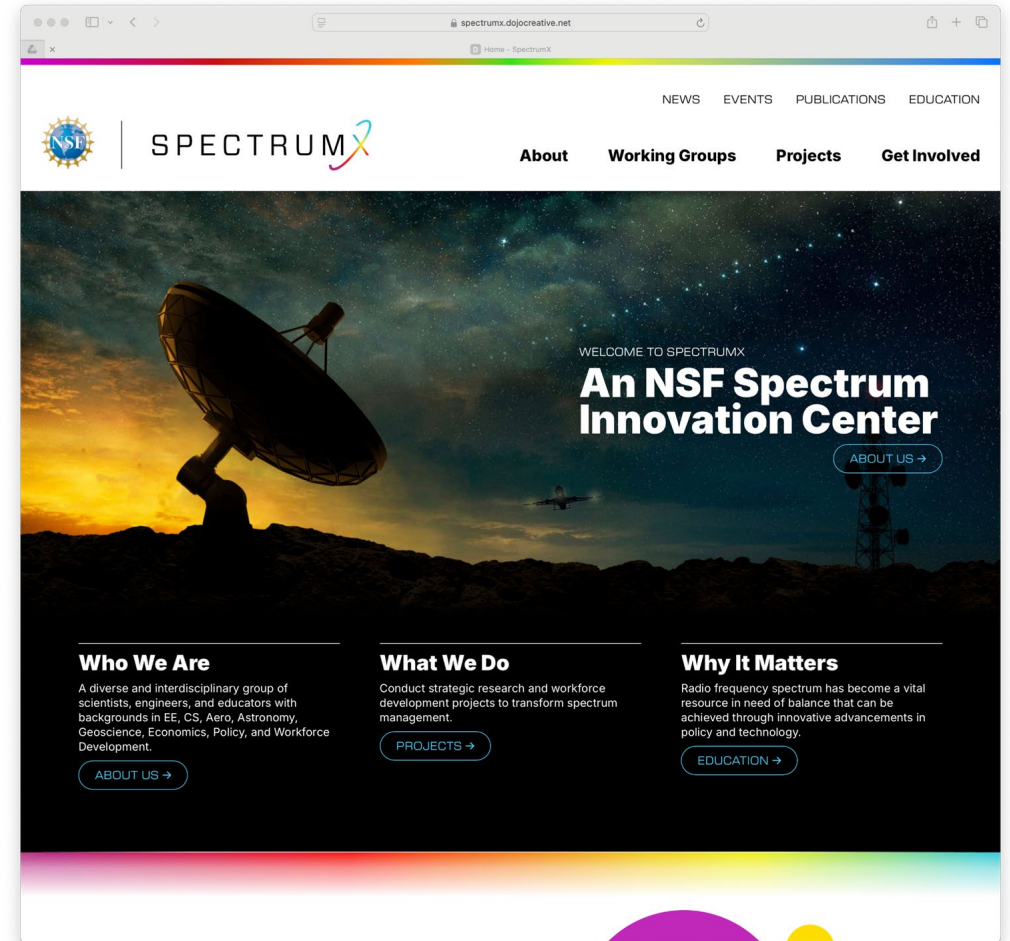

<https://spectrumx.org>





| SPECTRUM 



| SPECTRUM 

The word 'SPECTRUM' is written in a black, sans-serif font. To its right is a colorful graphic consisting of a blue line that curves upwards and then downwards, ending in a purple and pink gradient.