

Rethinking Space Astronomy in an Era of Abundance:

Accelerating Scientific Discovery via standardization, iteration, and scaled production

Why build space telescopes?

- To access all the other wavelengths... (gamma, x-ray, UV, IR, LWR)
- To remove contaminating foregrounds (New Horizons)
- To achieve stable observations (Kepler, TESS, Roman)
- Resolution beyond the seeing limit (Hubble, JWST)
- To build a high-efficiency fast observatory (*Swift*)
- **To Discover**
- **To Inspire**

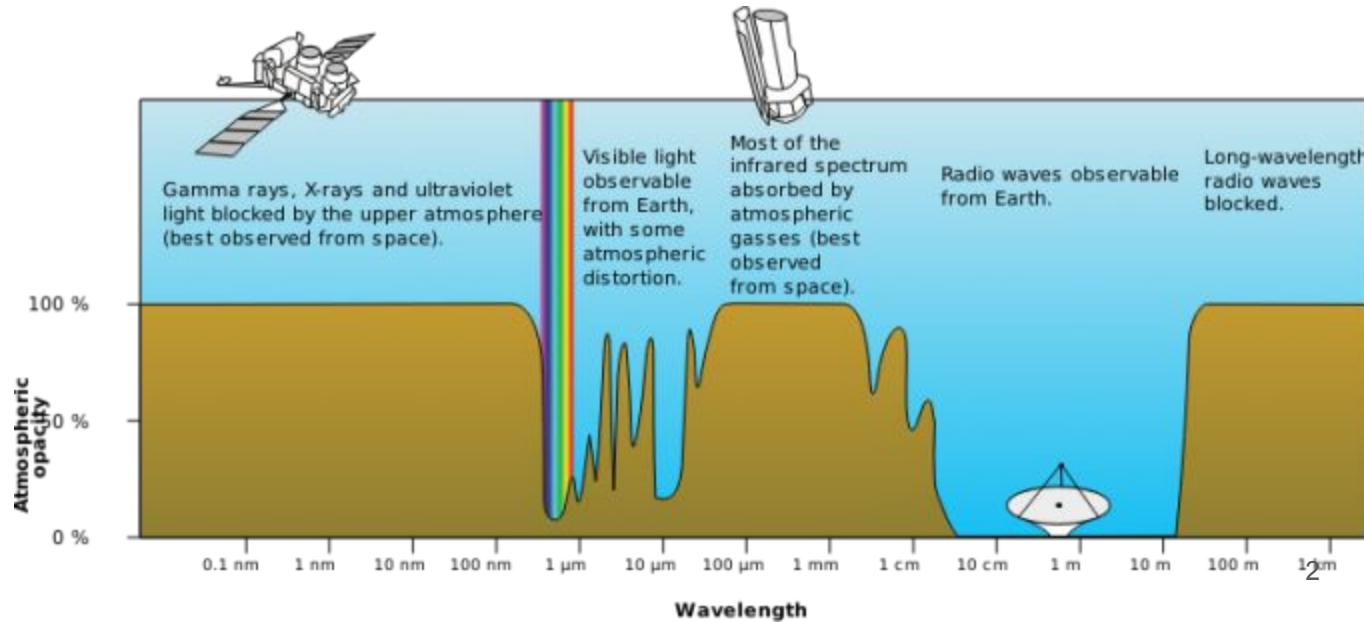



Pursue the greatest questions
and



Inspire the next generation



How do we learn more?

Astronomers compete for **precious time** on space telescopes.

Competitive proposal preparation can take **years**.

Even with high cost, **thousands of proposals** are submitted per year.

<10% of proposals are **awarded** time.

Bias for safe science, ‘guaranteed discovery’.

Figure 1: Acceptance rate by proposal size (hours)

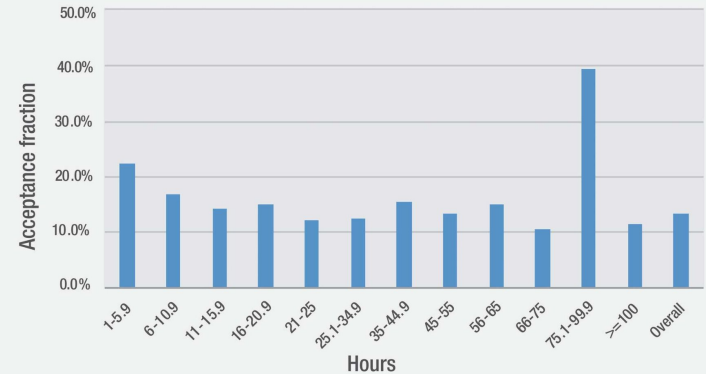
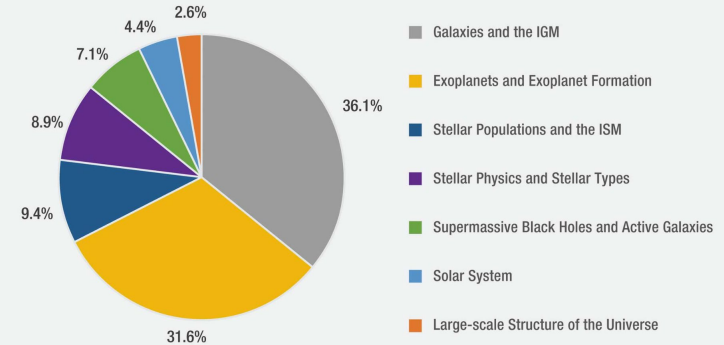

Figure 2: The fraction of time allocated by science category



What discoveries are we missing?

What kinds of experiments are structurally disfavored?

The programmatic model shapes the science – and the instruments

- Broad, general-purpose instruments
- Conservative designs (high TRL, low risk)
- Long, integrated observing programs
- Narrow / niche ideas filtered out early
- Instruments shaped by mission closure

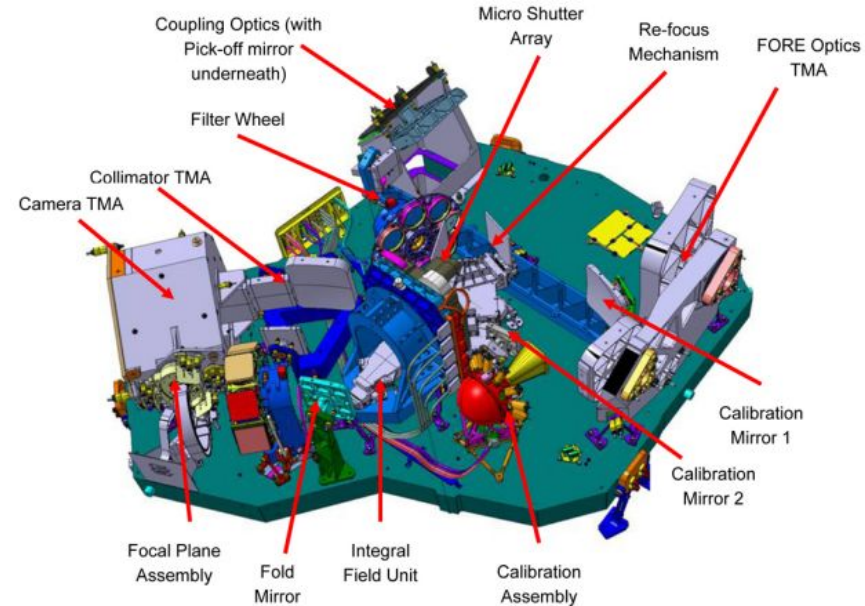

What if you only had to build the instrument?

On the ground, we already operate in a different model.

The telescope is infrastructure.

- instruments can be specialized
- they can be simpler
- they can be replaced or upgraded

You can focus on the measurement.

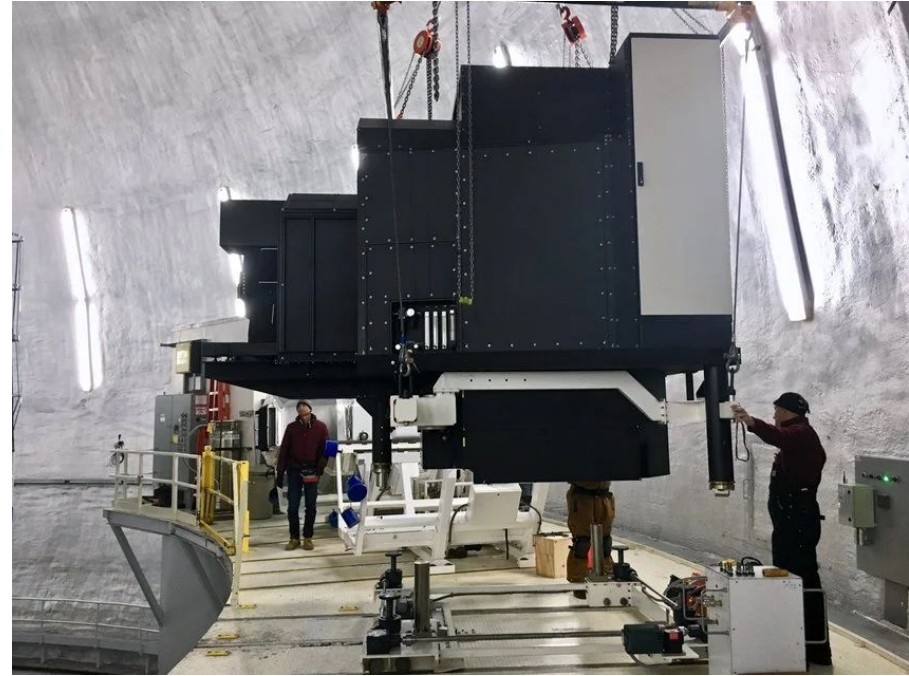

KCWI installation

Once the platform exists, both specialization and persistent access become much easier.

Many experiments are limited by cadence or access

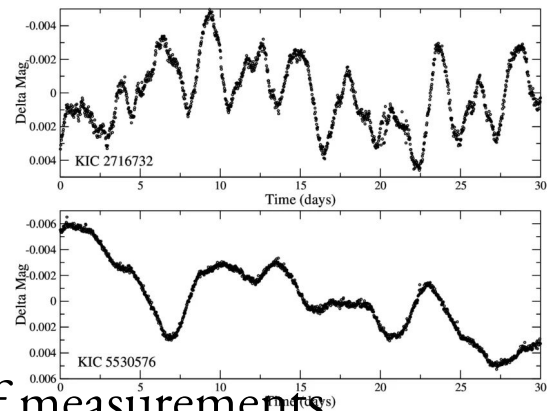
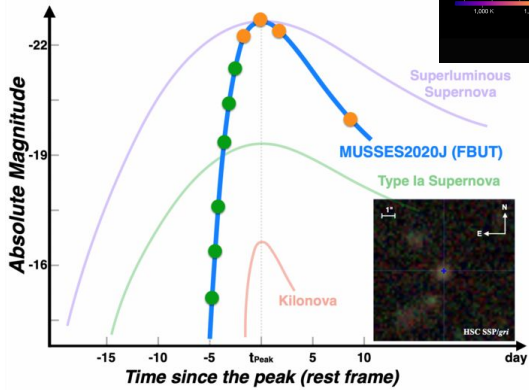
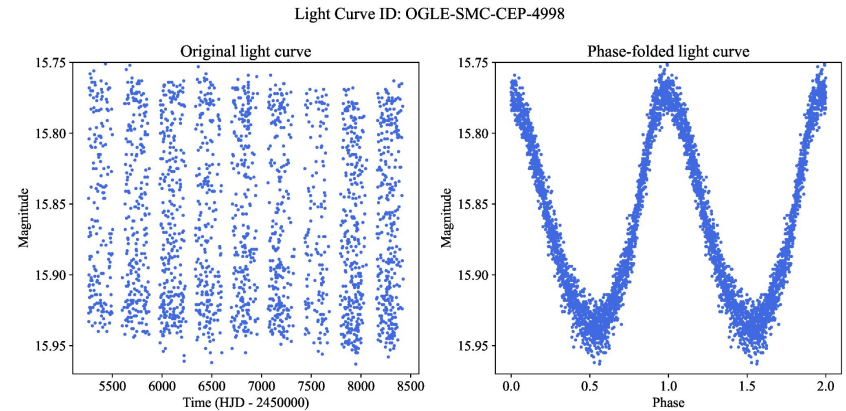
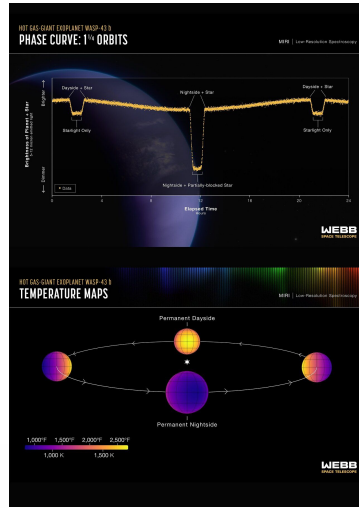
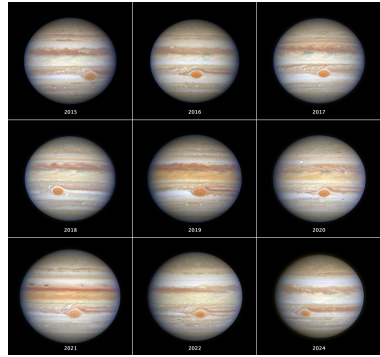

These are not niche cases — they are entire classes of measurements.

Highly specialized instruments are hard to justify at mission scale

- Very high-res UV-only spectrograph
- Single-line emission survey
- Dedicated high-cadence imager
- Narrow-field precision instrument
- MKID demonstrator
- Photonic beam-combiner
- Photonic coronagraph
- Name your favorite measurement+technology

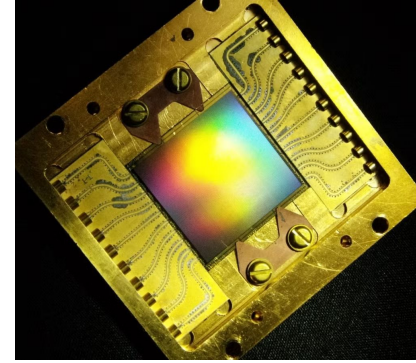

Mazin MKID (UCSB)

Bulk-optics Coronagraph

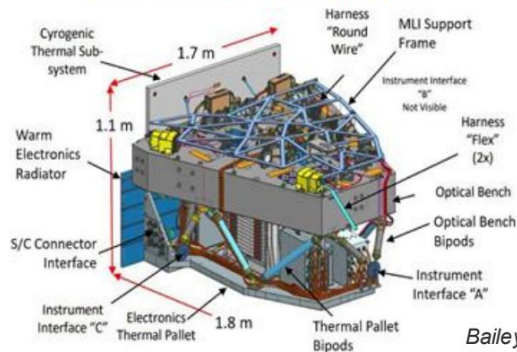

Integrated Photonic Coronagraph



NASA Tech Thursdays (2025)

A missing layer in the portfolio

- Flagship missions are optimized for the highest-priority science and are scarce
- Important science is left underserved when it is exploratory, operationally intensive, or instrument-driven
- Standardized platforms could add a complementary sustaining layer
- Persistent access, specialized instruments, faster iteration

Not a replacement for flagships.

An agile new layer in NASA's science ecosystem.

1 JWST

\$10 B USD

6 Kepler/Spitzer

200 SSTs

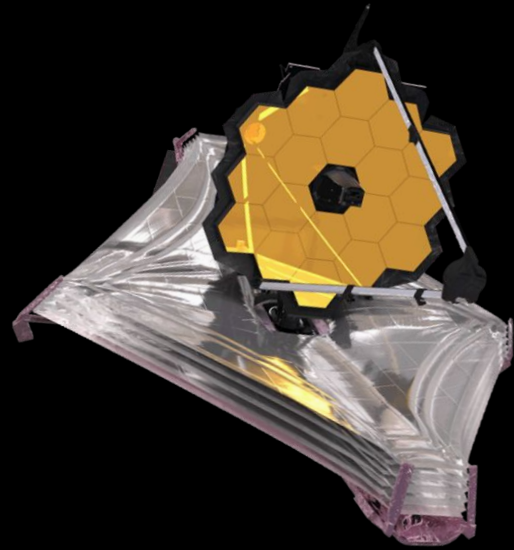

Illustrative Portfolio Comparison, not a policy prescription

Standardized Platforms Accelerate Discovery:

Microplate readers and standardized assays

Next-Gen Sequencing Platforms

PCR machines + reagents

Scanning/Transmission Electron Microscopes

Underwater exploration vehicles

Earth Observation (telescopes looking the wrong direction)

Orbital-class astronomy is next...

What would it take to enable this complementary mode?

Want

- Persistent access
- Specialized instruments
- Iteration
- Telescope time

Fighting

- Cost
- Challenging Engineering
- Risk
- Schedule

Standardized Space Telescopes for the Future of Scientific Discovery

April 21 – 23, 2025



24
participants



13
organizations



3-day
Symposium

STANDARDIZED SPACE TELESCOPES FOR THE FUTURE OF SCIENTIFIC DISCOVERY

Final Report 2025



Keck
INSTITUTE FOR SPACE STUDIES

What are the characteristics of a space telescope platform that enables more than it constrains?

Produce a high-performance space telescope **platform** that

- Will enable a large array of breakthrough science
- Provides high-resolution images over a large field
- Passes 150-1800 nm light (UV -> optical -> near-IR)
- Can be produced in quantity, minimal NRE
- Uses existing SOTA optics processes and coatings
- Enables flexible sensor integration, modular components
- Has generic bus capability, standardized interfaces
- Can be operated as a constellation, with high autonomy

At a cost that enables qualitatively different opportunities



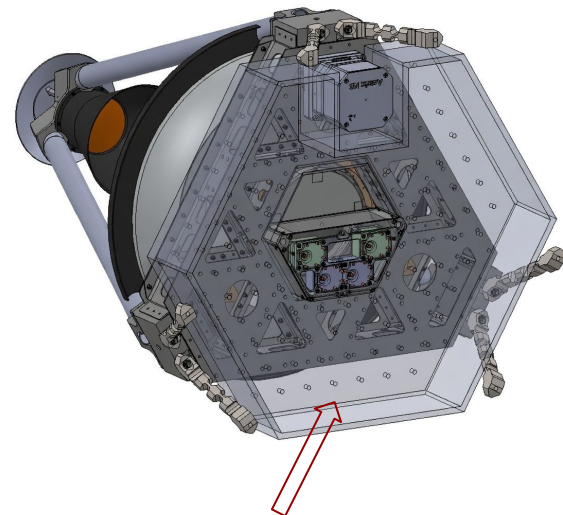
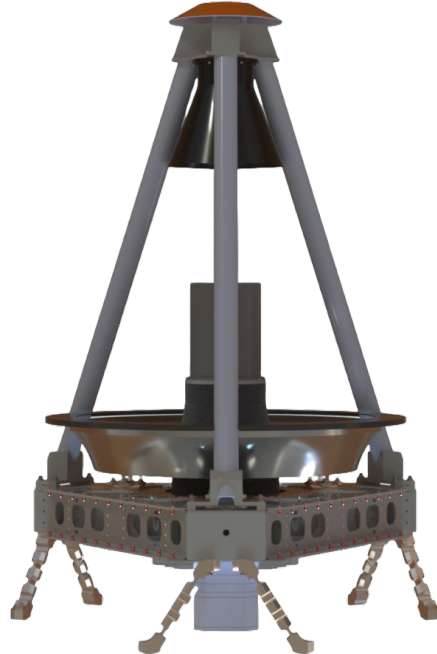
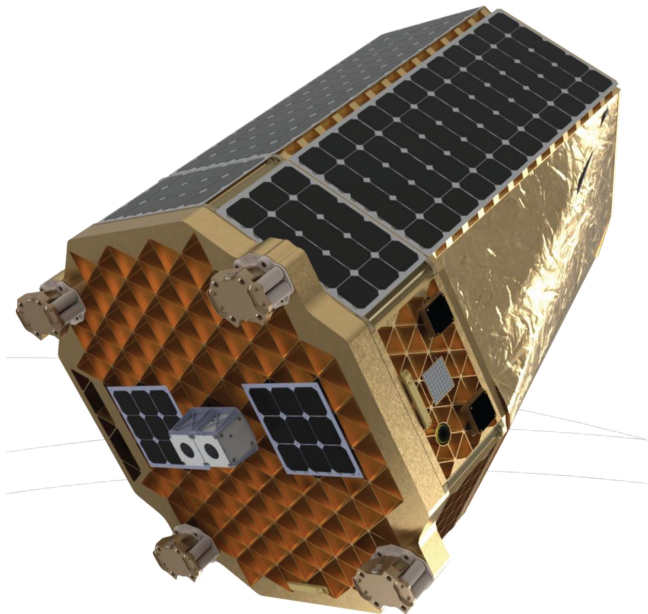

Post-focal Instrument Here

SPACE VEHICLE	STATS (as of March 2026)
Orbit	500-600 km SSO with eclipse
Next Launch	Manifested Oct 2027
Spacecraft Class	300 kg Full Plate XL / ESPA Grande
Stabilized Pointing Performance	Absolute Pointing Error: $<60'' 3\sigma$ Relative Pointing Error: $<0.05'' 3\sigma, >100s$
Communications	S-Band, Ka-Band, $> 50 \text{ GB / day}$

TELESCOPE	STATS (as of March 2026)
Aperture	498mm (diam.)
Focal Length	6000mm (f/12.05)
Optical Design	Three Mirror Anastigmat
Throughput	180-1500 nm, Throughput: $>65\%$
Ang. Resolution	0.28" (at 633 nm)
FOV	0.8 degree ² (1.7° x 0.5°)

Instrument Module	STATS (as of March 2026)
Mass Allocation	25 kg
Volume Allocation	70 x 70 x 20 cm ³
Thermal Allocation	$>40 \text{ W}$ heat rejection capacity, cold plate @ -40 C

Standard Telescope for Space Science. Designed for scale.

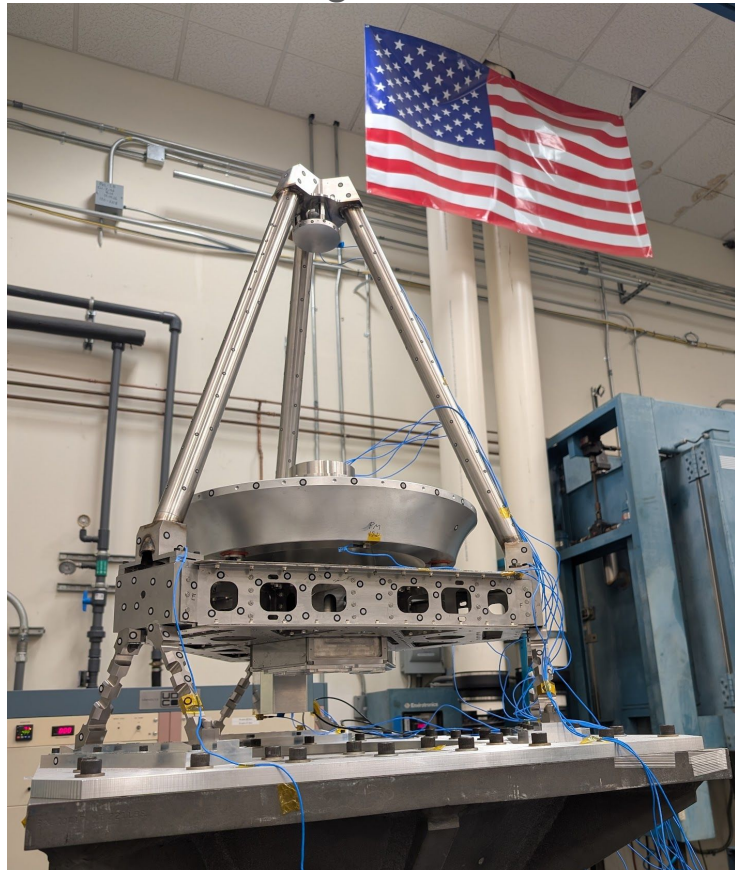

Vibration test campaign, March '26

High-performance telescope

Diffraction-limited, stabilized for long observations

Broad observatory capability

UV–NIR access on a common platform

Standardized instrument bay

For configurable science payloads

Hosted payload allocation

Mass / volume / power / thermal interfaces

Near-term flight

Manifested mission ('27) and repeatable architecture



Place Science
Instrument Here

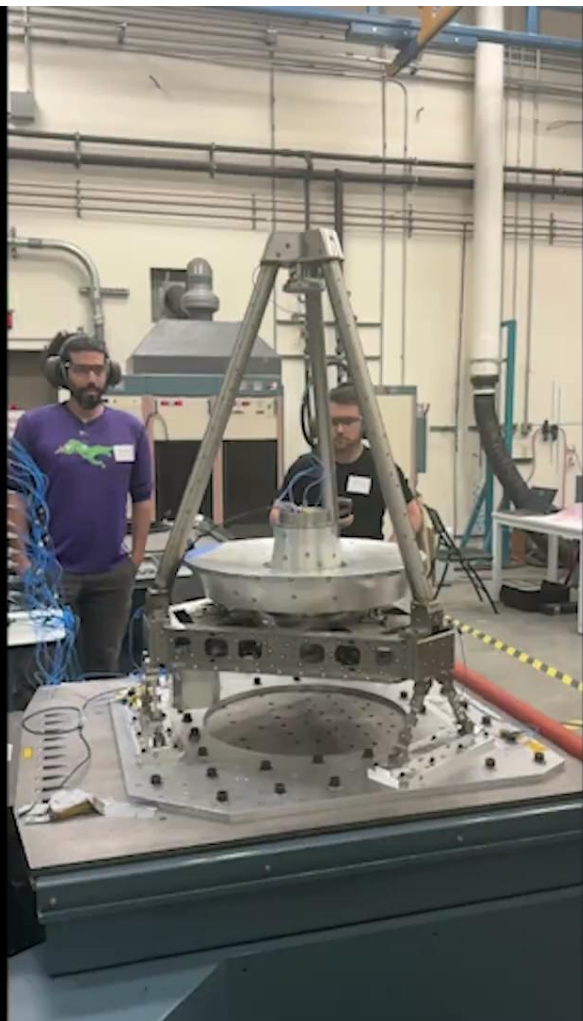

First Launch NLT Dec 1, 2027

- What science programs do you want to perform?
- What instruments do you want to build?
- What types of measurements are uniquely enabled by a fleet?
- ***What is the missing layer in the portfolio that would enable persistent access, specialized instruments, and faster iteration?***

What questions have we not yet dared to ask?

