



NOAA NESDIS Update

James Spann
Senior Scientist
Office of Space Weather Observations

NASEM CSSP March 2026

NOAA Space Weather Observations Update

SOLAR-1 (formerly SWFO-L1): Launched on September 24, 2025, this is the first satellite dedicated exclusively to space weather operations. It represents the final element of the Space Weather Follow-On Program.

Space Weather Next Program - This next-generation program is divided into three distinct orbital elements and an innovation element.

- **L1 SOLAR Series** - Both upcoming satellites in this series will feature a core instrument suite for solar and solar wind observations: a Space Weather Solar Coronagraph, X-ray Irradiance, Suprathermal Ion Sensor, Solar Wind Plasma Sensor, and Magnetometer. A partner-contributed instrument is also included.
- **SW GEO Series** - Status: Requirement and concept definition work is ongoing. The program is actively exploring the inclusion of a photospheric magnetic field imager in addition to particle, magnetic fields, and solar observing instruments.
- **SW LEO Series** - Status: Currently in the concept phase. The Space Weather Office (SWO) is evaluating the best approach to leverage commercial and partner assets and capabilities. Mitigation of space weather impacts on satellite orbits drag and communications is being considered.
- **Innovation** - The SWO office is partnering with NASA Technology Mission Directorate to develop a solar sail mission to go to a sub L1 location. Spacecraft studies and consideration instrument payloads are currently under way.

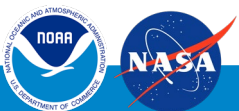



DSCOVR   

SOLAR-1  

EWS-G2   

JASON-3     

DMSP-F16/17/19   

NOAA-20/21   

SUOMI NPP   

GOES-WEST  

GOES-14  



GOES-17  

GOES-16  

GOES-EAST  

-  USA
-  FRANCE
-  NOAA
-  EUMETSAT
-  EUROPEAN COMMISSION
-  TAIWAN SPACE AGENCY (TASA)
-  EUROPEAN SPACE AGENCY
-  NASA
-  DEPARTMENT OF WAR

COMMERCIAL DATA PURCHASE

-  GEOSTATIONARY ORBIT
-  LOW EARTH ORBIT
-  DEEP SPACE

Current Observations Relevant for Space Weather Support

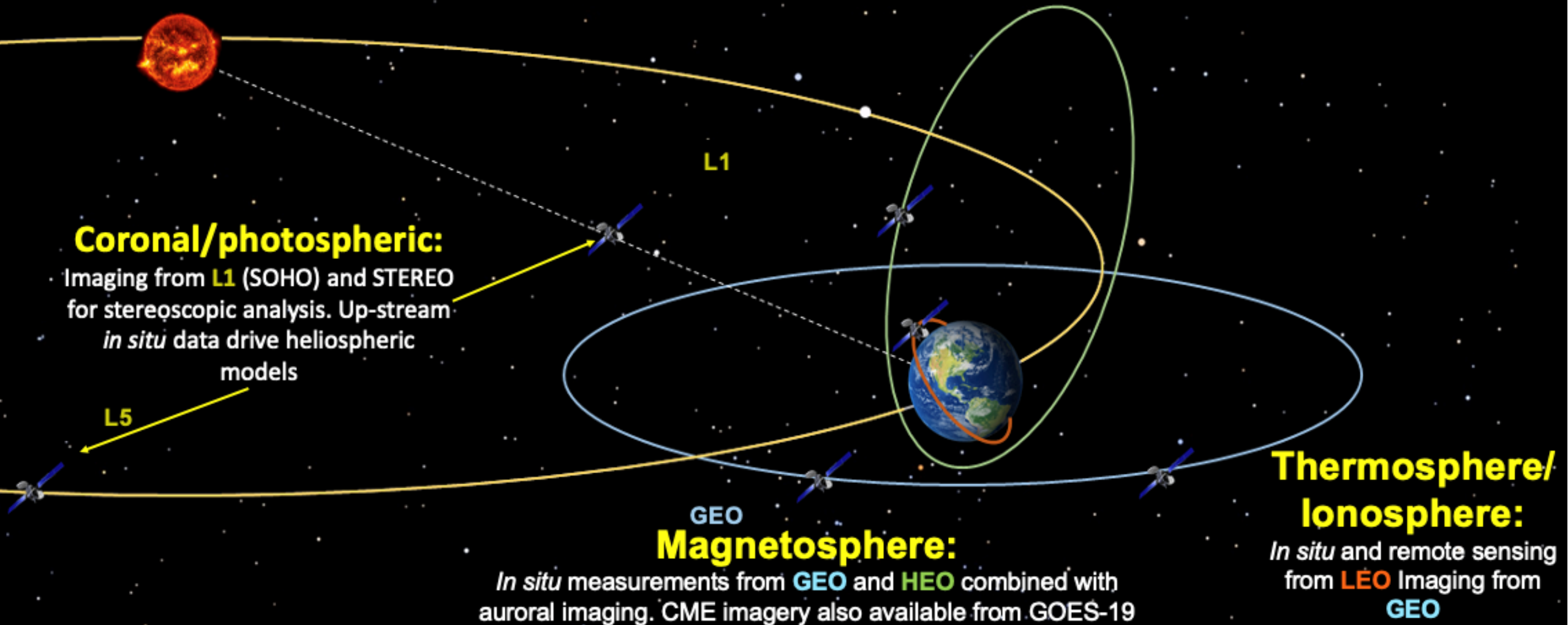

SOLAR-1 Launch,
(formerly SWFO-L1)
Kennedy Space
Center 09/24/25
7:30 AM



SOLAR-1 Status

NOAA has deployed its newest satellite, Space Weather Observations at L1 to Advance Readiness-1 (SOLAR-1, formerly SWFO-L1) to the Sun-Earth Lagrange 1 point

- Commissioning: Launch was on September 24, 2025, Lagrange Orbit Insertion (LOI) on January 23, 2026, Post-Launch Assessment Review (PLAR) on March 17, and Operational Handover Review (OHR) is planned for April 21.
- Product validation: Four beta-maturity product validation reviews (PVRs) completed; four provisional-maturity PVRs planned with IOC currently planned on April 22, 2026. First public-data/image announcements made.
- Data access: planned after each provisional review. Websites and servers for operational products (at SWPC) and retrospective ones (at NCEI) are ready.

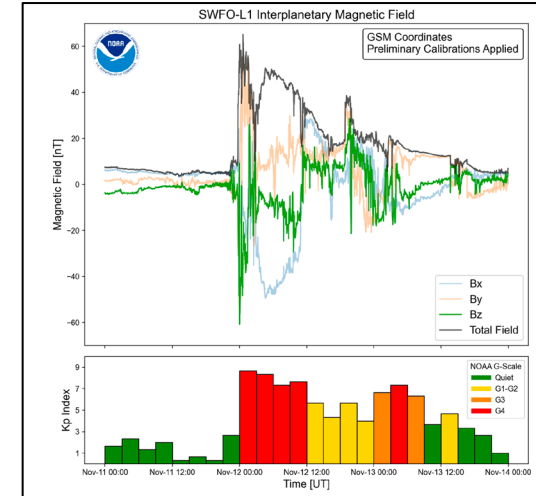

MAG first public data announcement

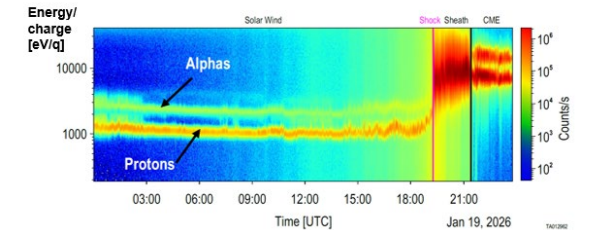

SwiPS: detailed view of Jan 19, 2026 shock, CME sheath, and cloud

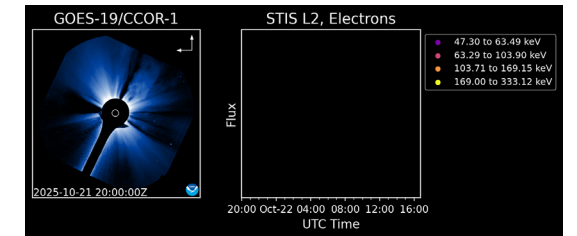

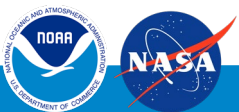

STIS (and CCOR-1): ejecta and SEPs from far-side CME, Oct 23, 2025

Mission	Instrument	Product(s)	Beta PVR	Provisional PVR	Full PVR	First Public Data/Image
SWFO-L1 L - Sep 2025	CCOR-2	Coronal imagery	NET Mar 24, 2026	Apr 22, 2026	Apr 22, 2027	NET Mar 11, 2026
	MAG	Interplanetary magnetic field	Jan 14, 2026	Mar 31, 2026	Mar 2, 2027	Dec 11, 2025
	STIS	Particle flux: suprathermal ions, electrons	Nov 12, 2025	NET Apr 8, 2026	Feb 25, 2027	Nov 26, 2025
	SWiPS	(n, V, T): protons (n, V): alpha particles	Dec 8, 2025	NET April 7, 2026	Feb 18, 2027	Dec 12, 2025

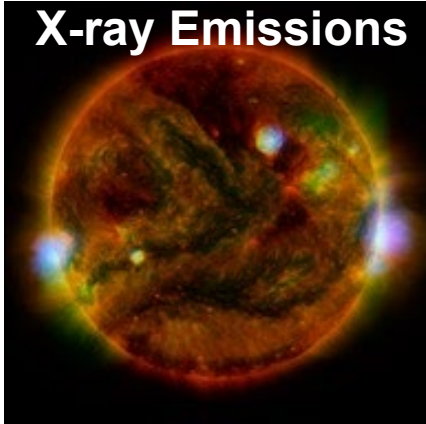

Space Weather Next SOLAR Series Observations

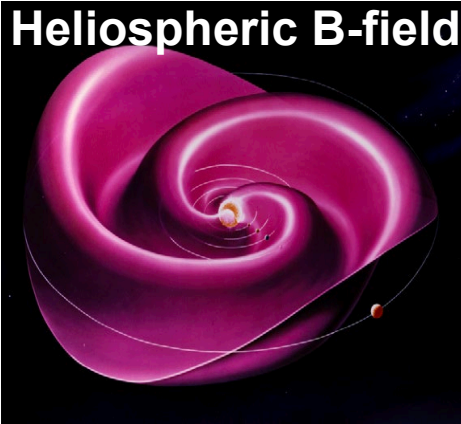
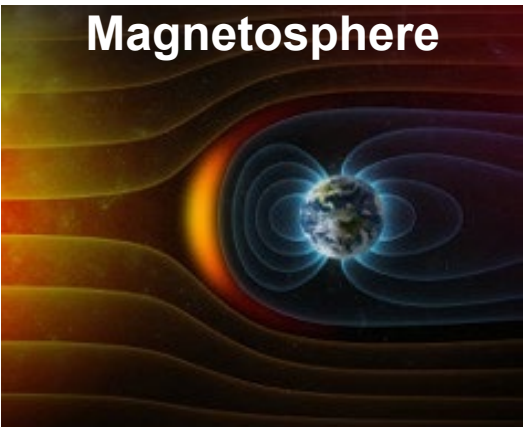
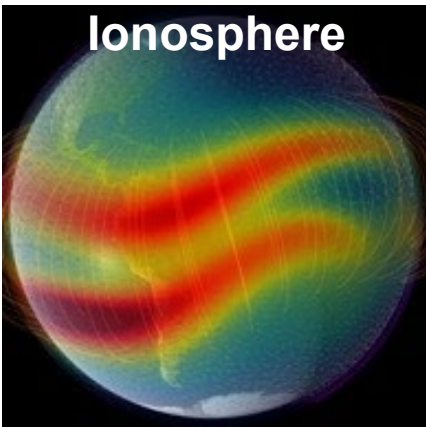
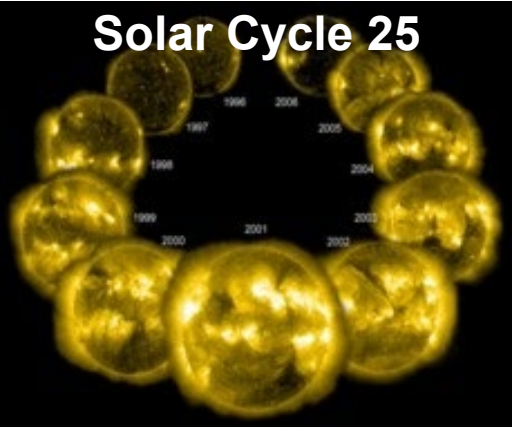
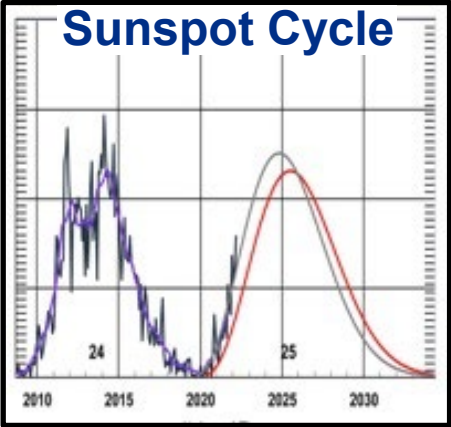
Solar Observations - Direct		Heliospheric Observations - Direct	
Coronal imagery  <p>2014/09/10 21:18</p>	X-ray Emissions 	Solar Wind 	Heliospheric B-field 
Drivers of Geospace Weather - Secondary		Long-Term Variations - Secondary	
Magnetosphere 	Ionosphere 	Solar Cycle 25 	Sunspot Cycle 

Solar Observations

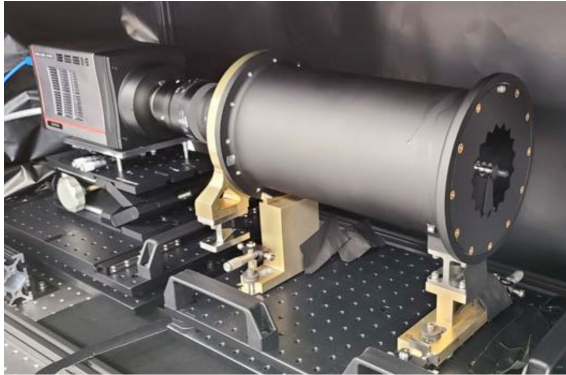

**Space weather
Solar Coronagraph
(SwSCOR)**

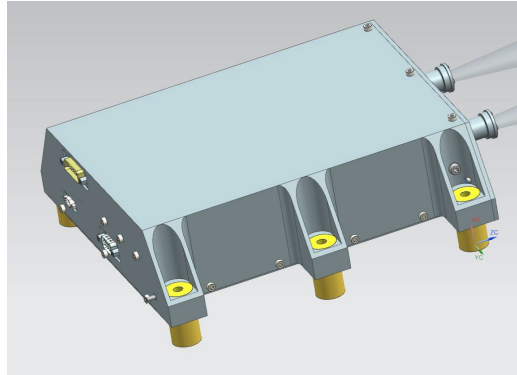

**X-ray Irradiance
(XFM Shown)**

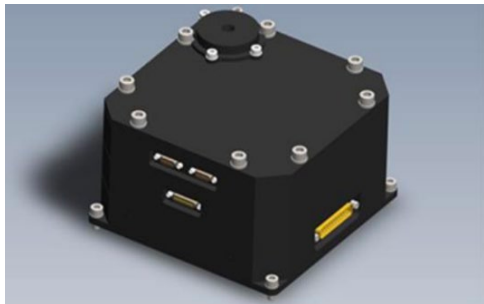

**Partner Contributed
Instrument: Energetic
Particle Spectrometer
Instrument (SOLAR-A)**

Heliospheric (Solar Wind) Measurements

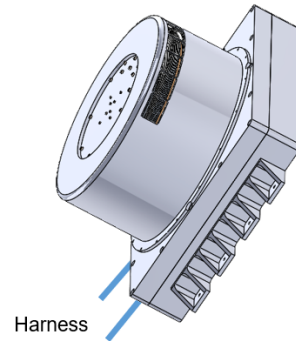

**Plasma Sensor
(SWiPS)**

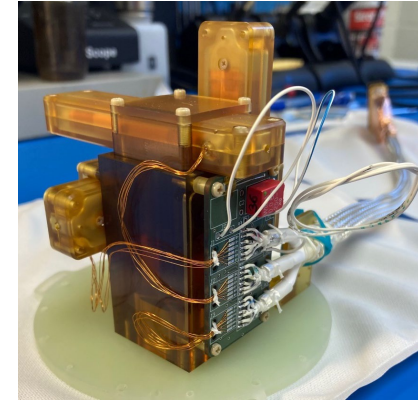

**Magnetometer
(MAG)**

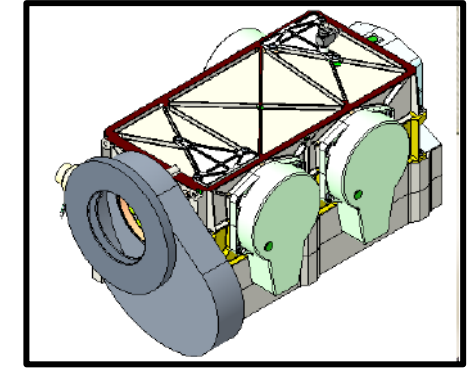

**Suprathermal Ion
Sensor (STIS)**

Instrument	Requirement	Performance
SwSCOR	$\leq 3 R_{Sun}$ to $\geq 22 R_{Sun}$	2.9 R_{Sun} to 22.5 R_{Sun}
X-ray Irradiance	1×10^{-9} – $1 \times 10^{-3} \text{ Wm}^{-2}$ in the 0.05 – 0.4 nm band range and 1×10^{-8} – $1 \times 10^{-3} \text{ Wm}^{-2}$ in the 0.1 – 0.8 nm band range	TBD
Plasma Sensor	200-2500 km/s	200-2500 km/s
Magnetometer	+/- 250 nT	+/- 450 nT
STIS	Ions: 50 keV – 2 MeV	Ions: 40 keV – 4 MeV SEPs: 5 MeV – 100 MeV Electrons: 50 keV - 5 MeV
PCI -EPSI	N/A	Electrons: 0.1-7 MeV (8 bins) Protons: 2- 200 MeV (8 bins) Ions: LET spectrum: 0.1 – 10 MeV cm ² /mg

Future Observations Relevant for Space Weather Support

L4 Exploring Collaboration

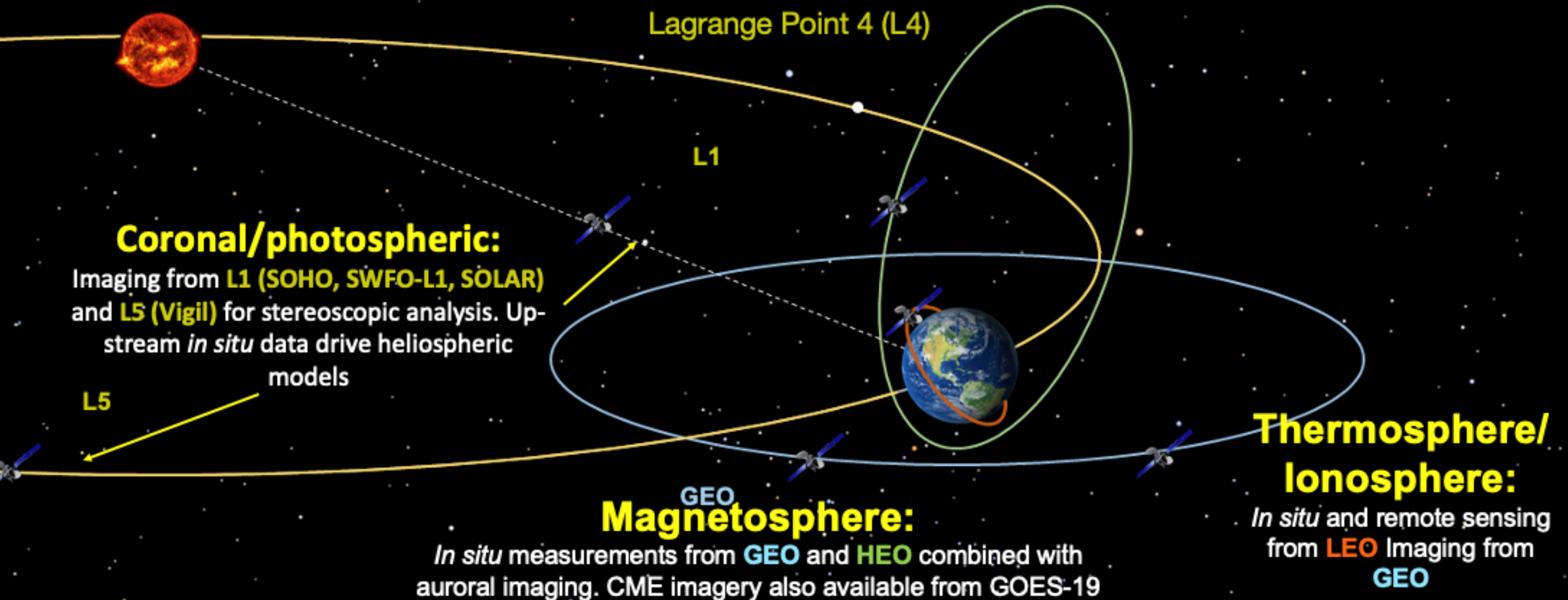

Lagrange Point 4 (L4)

L1

Coronal/photospheric:

Imaging from **L1 (SOHO, SWFO-L1, SOLAR)** and **L5 (Vigil)** for stereoscopic analysis. Upstream *in situ* data drive heliospheric models

L5

GEO Magnetosphere:

In situ measurements from **GEO** and **HEO** combined with auroral imaging. CME imagery also available from GOES-19

Thermosphere/Ionosphere:

In situ and remote sensing from **LEO** Imaging from **GEO**

Solar Sail Technology Optimization for Space Weather Observations

- **NOAA NESDIS is supporting several efforts related to solar sail technology for the sub-L1 observations.**
 - Examined sail-embedded Lightweight Deployable Integrable Antenna (LiDIA) arrays that enables high gain antenna arrays with low mass and stowage volume (advanced to TRL6 in Q1 2025).
 - Fabricating full-scale flight solar sail (in process).
 - Developing Compact Vector Helium Magnetometer (CVHM) low mass payload for future solar sail missions (in process).
 - Exploring additional sensors in collaboration with NASA/HPD
- **Solar Sail propulsion remains the most promising technology to increase lead time for geomagnetic storm**

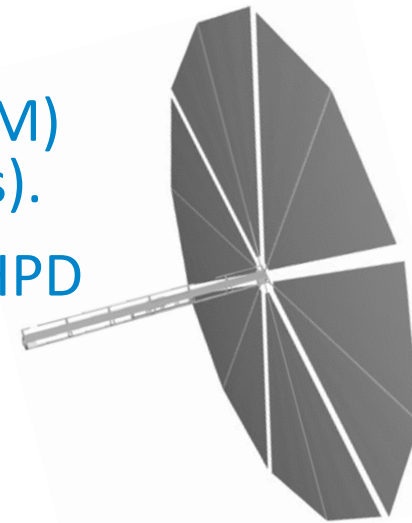
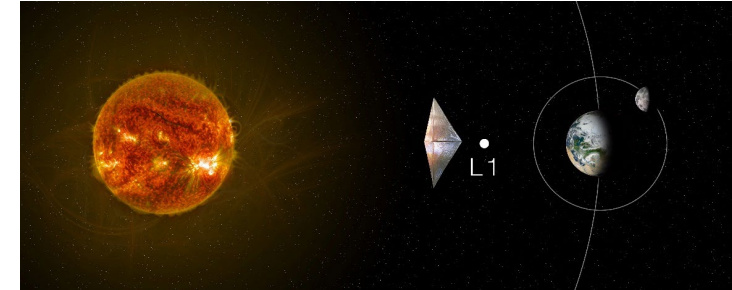

A sample of LiDIA
(Courtesy of D. Boyd,
NASA MSFC)